

50 years
manufacturing industrial machinery

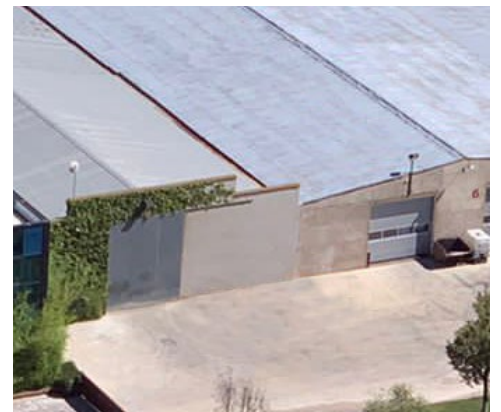

N NARGESA®

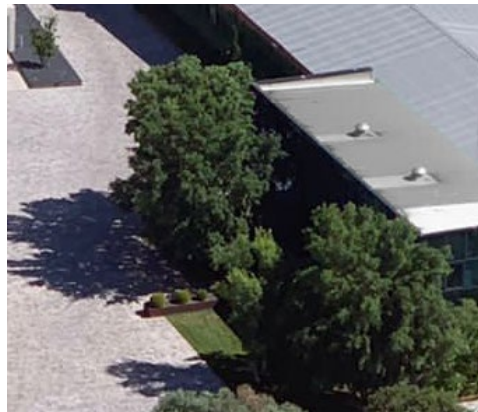

PRICE LIST
2026



Shipment everywhere
We arrange shipment anywhere in the world



3 years warranty
Up to 3 years warranty on your machine



We clear up your doubts
Our sales department offers personalized advice



Technical assistance
All our customers have access to technical support quickly and efficiently



Follow us

PRADA NARGESA, S.L.
Ctra. de Garrigàs a Sant Miquel s/n
17476 Palau de Santa Eulàlia (Girona) Spain
Tel. +34 972 568 085 nargesa@nargesa.com
www.nargesa.com



4 Laser welding equipments

Laser welding equipment MS20

11 Hydraulic iron worker

Hydraulic iron worker MX340G

Hydraulic iron worker MX700

30 Profile formers

Profile former MC150B

Profile former MC200

Profile former MC400

Profile former MC200H

Profile former MC550

Profile former MC550CNC

Profile former MC650

Profile former MC650CNC

44 Digital radius gauge

45 Non-Mandrel pipe benders

Non-Mandrel pipe bender CC60

Non-Mandrel pipe bender CC90

61 Forge twisting machines

Forge twisting machine MT150A

Forge twisting machine MT500A

67 Horizontal press brake

Horizontal press brake PP200CNC

88 PP200CNC Folding simulator software

89 Shears

Hydraulic shears C2006CNC

Hydraulic shears C3006CNC

91 Press brakes

Hydraulic press brake MP1500CNC

Hydraulic press brake MP3160CNC

99 Broaching machine

Broaching machine BM25

115 Power hammer

Power hammer PH50

121 Hot Forging Press

Hot Forging Press PV21

126 Forge furnaces

Forge furnace H1

Forge furnace H2

Forge furnace H3

128 End forging machines

End forging machine PC16

Wrought iron machine NF70

130 Iron embossing machine

Iron embossing machine NOA60

145 Hydraulic press for locks

Hydraulic press for locks PI85

148 Consumables

Hydraulic Oil SIL POWER HV46

Hydraulic Oil SIL POWER HV68



Laser welding equipments

Laser welding equipment MS20

The **MS20 Laser Welder** from Nargesa, with a power of 2000W, represents a significant advance in laser welding technology. It offers **surgical precision, high speed, and ease of use**.

Laser welding is a fusion process that **uses a laser beam to join different materials**, such as carbon steel, stainless steel, aluminum, brass, copper, etc., **with or without filler material**. Its **extreme precision, high speed, and ease of use** make it the most cost-effective welding process, not only manually but also in **robotic automation**. Entirely designed and manufactured at our facilities in Spain, making us the **only European manufacturer**.

Reference	100-19-01-001
Power	2000W / 2Kw.
Voltage	220 / 240v. Single-phase
Frequency	50 / 60Hz
Wavelength	1080nm
Fiber hose length	10 m / 393,7"
Fiber diamete	25 µm
Guide laser	630-650nm / 0,5-1Mw
Maximum laser beam opening	5mm/0,2" Single Wire Feed 8mm/0,31" Double Wire Feed
Power consumption	4Kw
Maximum amperage	16A
Dimensions	690x870x1780 mm
Weight	615 Kg
PRICE	18.224,00 €



NEW



Ready to weld, cut, and clean

Three different operations with the same equipment. Weld with or without filler, clean welds, or cut sheet metal, working with cutting-edge technology. This equipment offers the greatest weld depth on the market, reaching up to 6 mm in carbon steel, stainless steel, and aluminum.



Intuitive interface and Plug & Play delivery

Its intuitive interface and low complexity mean that, with minimal training, the equipment can be operated quickly and safely by non-specialized personnel. Delivered with the basic parameters configured, ready to plug in and start working.



Expert technical support, free and unlimited

100% personalized technical support service, at no extra cost and with no limits. With 4.0 technology, we connect remotely to the MS20 to adjust parameters, perform updates, or evaluate any abnormal situations.



Accessories for Laser welding equipment MS20

Electronic Laser Protection Mask



REF: 080-MSL-00023

Auto-darkening electronic helmet with adjustable sensitivity and solar-powered photosensor for laser work. Wraparound polymer shell with adjustable harness and specific front laser filter. Side control for shade adjustment. Designed to protect the operator's eyes and face during laser welding and marking operations, according to filter configuration.

- **Full eye and face protection** against laser radiation (per installed filter), sparks, and light projections.
- **Adjustable auto-darkening:** automatic shade change upon emission detection (response time and darkness level configurable).
- **Comfort for long use:** lightweight, balanced helmet with adjustable headgear (diameter, height, and depth) for superior comfort.
- **High visibility in standby:** light mode for positioning and part preparation with precision.
- **Certified safety and marking:** compliant with the Standard technical rules and the essential requirements of Annex II of PPE Regulation (EU) 2016/425 (EN ISO 16321-1:2022, EN ISO 16321-2:2021, ISO 16321-1:2021/Amd.1:2024, EN 207:2017). Marking: eye protection 16321 LP W4 1-M, 950-100 D LB7 IR LB8 LP CE; face and head protection 16321 LP W4 1-M, 900-1100 D LB5 IR LB8 LP CE; automatic welding filter 11961-PZA-24.

PRECIO: 460,00 €

Laser Protection Mask



REF: 080-MSL-00022

Passive laser welding mask with specific green laser visor. Lightweight wraparound helmet with adjustable headgear and side adjustment. Designed to protect the operator's eyes and face during manual laser welding and auxiliary operations against UV exposure.













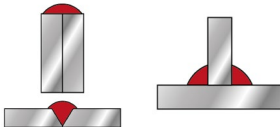

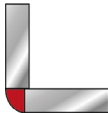

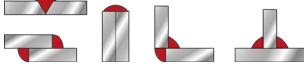

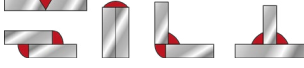

- **Eye and face protection** against laser radiation and light projections during welding.
- **Simplicity and reliability:** no electronics or batteries; minimal maintenance.
- **Comfort:** adjustable headgear for diameter, height, and depth.
- **Wide field of view** with large passive visor.
- **Certified safety and marking:** compliant with the essential requirements of Annex II of PPE Regulation (EU) 2016/425, in accordance with EN ISO 16321-2:2021 and EN 207:2017. Marking: eye protection 16321 LP W4 1-M, 950-100 D LB7 IR LB8 LP CE; face and head protection 16321 LP W4 1-M, 900-1100 D LB5 IR LB8 LP CE.

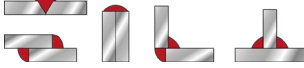
PRECIO: 160,00 €

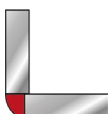

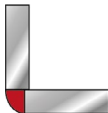

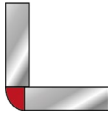

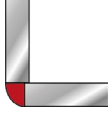



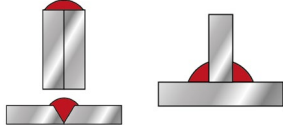

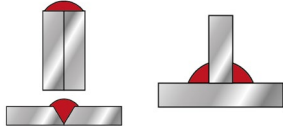
Accessories for Laser welding equipment MS20

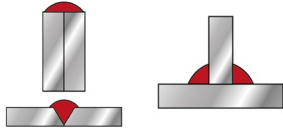
Laser Welding Nozzles

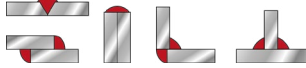
Laser welding nozzles with and without filler wire feed, for different welding applications.

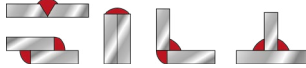

	Descripción	Hilos	Tipo de soldadura	Ø Hilo	Modelo	PRICE
	Ref: 080-MSL-00411 Nozzle for autogenous welding, for flat welds, inside corners and outside corners.	-		-	A	5,00 €
	Ref: 080-MSL-00412 Nozzle for autogenous welding, for flat welds or inside corners.	-		-	B	5,00 €
	Ref: 080-MSL-00413 Nozzle for autogenous welding, for outside corner welding.	-		-	C	5,00 €
	Ref: 080-MSL-00414 Nozzle for welding with filler wire up to 1.0 mm, for flat welding, inside corners and outside corners.	1		1.0 mm	AS-10	5,00 €
	Ref: 080-MSL-00415 Nozzle for welding with filler wire up to 1.2 mm, for flat welding, inside corners and outside corners.	1		1.2 mm	AS-12	5,00 €
	Ref: 080-MSL-00416 Nozzle for welding with filler wire up to 1.6 mm, for flat welding, inside corners and outside corners.	1		1.6 mm	BS-16	5,00 €
	Ref: 080-MSL-00417 Nozzle for welding with filler wire up to 2.0 mm, for flat welding, inside corners and outside corners.	1		2.0 mm	BS-20	5,00 €
	Ref: 080-MSL-00418 Nozzle for welding with filler wire up to 1.0 mm, for outside corner welding.	1		1.0 mm	CS-10	5,00 €
	Ref: 080-MSL-00419 Nozzle for welding with filler wire up to 1.2 mm, for outside corner welding.	1		1.2 mm	CS-12	5,00 €
	Ref: 080-MSL-00420 Nozzle for welding with filler wire up to 1.6 mm, for outside corner welding.	1		1.6 mm	CS-16	5,00 €
	Ref: 080-MSL-00421 Nozzle for welding with filler wire up to 1.2 mm, for outside corner welding.	1		1.2 mm	ES-12	5,00 €

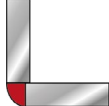
Accessories for Laser welding equipment MS20

Description	Wires	Type of welding	Wire Ø	Model	PRICE
 Ref: 080-MSL-00422 Nozzle for welding with filler wire up to 1.0 mm, for flat welding and inside corners.	1		1.0 mm	DS-10	5,00 €
 Ref: 080-MSL-00423 Nozzle for welding with filler wire up to 1.2 mm, for flat welding and inside corners.	1		1.2 mm	DS-12	5,00 €
 Ref: 080-MSL-00424 Nozzle for welding with filler wire up to 1.6 mm, for flat welding and inside corners.	1		1.6 mm	DS-16	5,00 €
 Ref: 080-MSL-00425 Nozzle for welding with dual filler wire feed up to 1.2 mm, for flat welding, inside corners and outside corners.	2		1.2 mm	AS-12D	5,00 €
 Ref: 080-MSL-00426 Nozzle for welding with dual filler wire feed up to 1.6 mm, for flat welding, inside corners and outside corners.	2		1.6 mm	AS-16D	5,00 €
 Ref: 080-MSL-00427 Nozzle for welding with dual filler wire feed up to 2.0 mm, for flat welding, inside corners and outside corners.	2		2.0 mm	AS-20D	5,00 €
 Ref: 080-MSL-00431 Nozzle for welding with filler wire up to 1.6 mm, for outside corner welding.	1		1.6 mm	ES-16 FS-16	5,00 €







Nozzle and tip for cutting

Nozzle and tip for laser cutting. One set is supplied, consisting of 1 nozzle and 1 tip.

Description	Model	PRICE
 Ref: 080-MSL-00428 Nozzle and tip set for sheet metal cutting.	CT-15	7,00 €
 Ref: 080-MSL-00429 1.5 mm tip for the cutting nozzle.	CT-15	4,00 €





Accessories for Laser welding equipment MS20

Steel, Teflon and Graphite Liners

	Description	PRICE
	Ref. 080-MSL-00301 Steel Liner Blue 0.6-0.8, 5m Welding liner for 0.6–0.8 mm steel wire, 5 m	9,00 €
	Ref. 080-MSL-00302 Steel Liner Red 1.0-1.2, 5m Welding liner for 1.0–1.2 mm steel wire, 5 m	9,00 €
	Ref. 080-MSL-00304 Teflon Liner Blue 0.6-0.8, 5m Welding liner for 0.6–0.8 mm aluminium wire, 5 m	20,00 €
	Ref. 080-MSL-00305 Teflon Liner Red 1.0-1.2, 5m Welding liner for 1.0–1.2 mm aluminium wire, 5 m	20,00 €
	Ref. 080-MSL-00306 Teflon Liner Yellow 1.4-1.6, 5m Welding liner for 1.4–1.6 mm aluminium wire, 5 m	20,00 €
	Ref. 080-MSL-00307 Graphite Liner 1.0-2.0, 5m Welding liner for 1.0–2.0 mm aluminium wire, 5 m	26,00 €
	Ref. 080-MSL-00308 Steel Liner 1.2-2.0, 5m Welding liner for 1.2–2.0 mm steel wire, 5 m	9,00 €

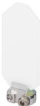





Accessories for Laser welding equipment MS20

Lenses

	Description	PRICE
	Ref. 080-MSL-00323 Reflective Lens Reflective lens for welding, cutting and weld bead cleaning.	115,00 €
	Ref. 080-MSL-00321 Focusing Lens D20 × F150 × T3 Focusing lens D20 F150 for welding, cutting and weld bead cleaning.	43,00 €
	Ref. 080-MSL-00320 Collimating Lens D16 × F60 × T3 Collimating lens D16 for welding, cutting and weld bead cleaning.	43,00 €
	Ref. 080-MSL-00332 Protective Lens Protective lens for welding, cutting and weld bead cleaning.	5,00 €

Feed rollers

Feed rollers with double “U” or “V” groove for different wire sizes and materials.

	Ref.	Description	Wires Ø	PRICE
	080-MSL-00326	Roller 0.8–1.0 U U-groove feed roller for aluminum wire.	0,8 y 1,0mm.	16,00 €
	080-MSL-00327	Roller 1.2–1.6 U U-groove feed roller for aluminum wire.	1,2 y 1,6mm.	16,00 €
	080-MSL-00328	Roller 1.6–2.0 U U-groove feed roller for aluminum wire.	1,6 y 2,0 mm.	16,00 €
	080-MSL-00329	Roller 0.8–1.0 V V-groove feed roller for steel wire.	0,8 y 1,0mm.	16,00 €
	080-MSL-00330	Roller 1.2–1.6 V V-groove feed roller for steel wire.	1,2 y 1,6 mm.	16,00 €
	080-MSL-00331	Roller 1.6–2.0 V V-groove feed roller for steel wire.	1,6 y 2,0 mm.	16,00 €

Accessories for Laser welding equipment MS20

Graded Tube











REF: 080-MSL-00334

Graduated focusing tube for nozzles.

PRICE: 27,00 €

Feed noozles

Wire feed guide noozles.

	Ref.	Description	Wires	Wire Ø	PRICE
	080-MSL-00402	Double wire feed nozzle 1.0 mm Double wire feed guide nozzle, 1.0 mm.	2	1,0 mm.	5,00 €
	080-MSL-00403	Double wire feed nozzle 1.2 mm Double wire feed guide nozzle, 1.2 mm.	2	1,2 mm.	5,00 €
	080-MSL-00404	Double wire feed nozzle 1.6 mm Double wire feed guide nozzle, 1.6 mm.	2	1,6 mm.	5,00 €
	080-MSL-00405	Double wire feed nozzle 2.0 mm Double wire feed guide nozzle, 2.0 mm.	2	2,0 mm.	5,00 €
	080-MSL-00406	Single wire feed nozzle 0.8 mm Wire feed guide nozzle, 0.8 mm.	1	0,8 mm.	3,00 €
	080-MSL-00407	Single wire feed nozzle 1.0 mm Wire feed guide nozzle, 1.0 mm.	1	1,0 mm.	3,00 €
	080-MSL-00408	Single wire feed nozzle 1.2 mm Wire feed guide nozzle, 1.2 mm.	1	1,2 mm.	3,00 €
	080-MSL-00409	Single wire feed nozzle 1.6 mm Wire feed guide nozzle, 1.6 mm.	1	1,6 mm.	3,00 €
	080-MSL-00410	Single wire feed nozzle 2.0 mm Wire feed guide nozzle, 2.0 mm.	1	2,0 mm.	3,00 €

Hydraulic iron worker

Hydraulic iron worker MX340G

The Hydraulic Punching Machine MX340G Nargesa main feature is its versatility. It can make several functions as punching operations in metal sheet, flat bar, pipe, angle, U-T-UPN-IPN profiles, folding, cutting, tube notching, inlaying, punching, bending sheets, stamping... It can be suitable for any other kind of tooling.

Reference	100-02-01-002
Engine power	2,2 KW / 3 HP
Three-phased tension	230 / 400 V
Hydraulic power	40 Tn
Working speed	7,1 mm/s
Return speed	9,3 mm/s
Punch displacement	100 mm
Neck	180 mm
Tooling support table	245x265 mm
Dimensions	690x870x1780 mm
Weight	615 Kg
PRICE	7.605,00 €



Accessories for Hydraulic iron worker MX340G

Fitting nuts for punches MX340



TAP



ATAP

Reference	Type	Fitting nuts for punches	PRICE
120-02-01-00011	TAP28	Fitting nuts for punches N28 <i>Standard</i>	87,00 €
140-02-01-00019	TAP40	Fitting nuts for punches N40	87,00 €
140-02-01-00020	TAP50	Fitting nuts for punches N50	87,00 €
140-02-01-00021	TAP60	Fitting nuts for punches N60	87,00 €
125-02-01-00002	ATAP	Fitting part for TAP60	71,00 €

Fitting parts for dies MX340



CAB

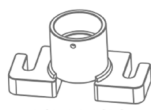

PORTABASES

Reference	Type	Fitting for dies	PRICE
120-02-01-00012	N46	Fitting for dies N46 <i>Standard</i>	60,00 €
140-02-01-00024	N60	Fitting for dies N60	60,00 €
140-02-01-00025	N78	Fitting for dies N78	60,00 €
140-02-01-00037	N100	Base holder for dies N100	221,00 €
140-02-01-00038	N125	Base holder for dies N125	236,00 €

Standard round punches MX340

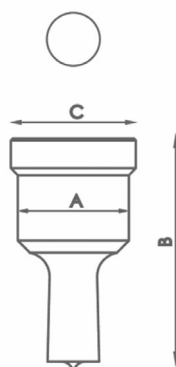

Type	Available sizes in mm Ø	A	B	C	PRICE
N28	3/3'5/4/4'5/5/5'5/6/6'5/7/7'5/8 8'5 /9mm up to 28mm from 0'5 in 0'5mm	28 mm	58 mm	31,5 mm	22,00 €/uni
N40	29/30/31/32/33/34/35 36/37/38/39/40mm	40 mm	64 mm	43,5 mm	32,00 €/uni
N50	41/42/43/44/45/46/47/48/49/50mm	50 mm	58 mm	54 mm	105,00 €/uni
N60	52/54/56/58/60mm	60 mm	58 mm	64 mm	112,00 €/uni
N75	62/64/66/68/70/72/74mm	75 mm	58 mm	79 mm	112,00 €/uni
N100	76/78/80/82/84/86/88 90/92/94/96/98/100mm	100 mm	58 mm	104 mm	169,00 €/uni

For different sizes, please ask the manufacturer

Accessories for Hydraulic iron worker MX340G

Standard square punches MX340

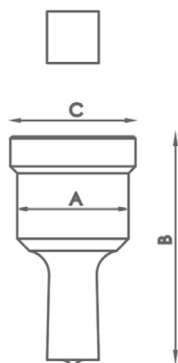

Type	Available sizes in mm	A	B	C	PRICE
N28	4/5/6/7/8/9/10/11/12/13/14/15 16/17/18/19/20mm	28 mm	58 mm	31,5 mm	42,00 €/uni
N40	21/22/24/26/28mm	40 mm	64 mm	43,5 mm	73,00 €/uni
N50	31/33/35mm	50 mm	58 mm	54 mm	135,00 €/uni
N75	40/44/48/53mm	75 mm	58 mm	79 mm	158,00 €/uni
N100	58/64/70mm	100 mm	58 mm	104 mm	200,00 €/uni

For different sizes, please ask the manufacturer

Standard rectangular punches MX340

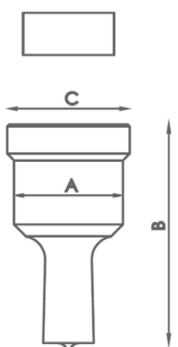

Type	Available sizes in mm	A	B	C	PRICE
N28	7x10/7x15/9x13/9x19/11x17/11x23 13x19/15x21mm	28 mm	58 mm	31,5 mm	42,00 €/uni
N40	13x25/15x27/17x25/19x30/20x34mm	40 mm	64 mm	43,5 mm	73,00 €/uni
N50	25x43mm	50 mm	58 mm	54 mm	135,00 €/uni
N75	25x70mm	75 mm	58 mm	79 mm	158,00 €/uni
N100	25x96mm	100 mm	58 mm	104 mm	200,00 €/uni

For different sizes, please ask the manufacturer

Standard oval punches MX340

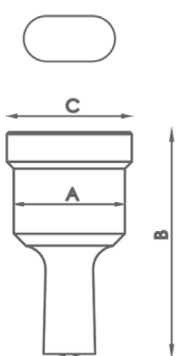

Type	Available sizes in mm	A	B	C	PRICE
N28	7x10/7x15/7x20/9x13/9x19/11x17/11x23 11x27/13x18/13x22/13x27/15x20/15x24 15x27/17x22/17x26/19x26/21x27mm	28 mm	58 mm	31,5 mm	42,00 €/uni
N40	13x31/15x31/17x31/17x40/19x31 19x40/21x31/21x40mm	40 mm	64 mm	43,5 mm	73,00 €/uni
N50	25x45/25x50mm	50 mm	58 mm	54 mm	135,00 €/uni
N75	27x63/27x75mm	75 mm	58 mm	79 mm	159,00 €/uni
N100	30x87/30x100mm	100 mm	58 mm	104 mm	199,00 €/uni

For different sizes, please ask the manufacturer

Accessories for Hydraulic iron worker MX340G

Standard round dies MX340



Type	Available sizes in mm	A	B	PRICE
N46	3/3,5/4/4,5/5/5,5/6/6,5/7/7,5/8/8,5 9mm up to 28mm from 0,5 in 0,5mm	46 mm	28,5 mm	17,00 €/uni
N60	29/30/31/32/33/34/35/36/37/38/39/40mm	60 mm	32 mm	21,00 €/uni
N78	41/42/43/44/45/46/47/48/49/50mm	78 mm	28,5 mm	86,00 €/uni
N100	52/54/56/58/60/62/64/66/68/70/72/74mm	100 mm	28,5 mm	113,00 €/uni
N125	76/78/80/82/84/86/88/90/92/94/96/98/100mm	125 mm	28,5 mm	132,00 €/uni

For different sizes, please ask the manufacturer

Standard square dies MX340

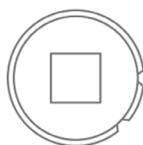

Type	Available sizes in mm	A	B	PRICE
N46	4/5/6/7/8/9/10/11/12/13/14/15/16/17/18/19/20mm	46 mm	28,5 mm	50,00 €/uni
N60	21/22/24/26/28mm	60 mm	32 mm	58,00 €/uni
N78	31/33/35mm	78 mm	28,5 mm	128,00 €/uni
N100	40/44/48/53mm	100 mm	28,5 mm	163,00 €/uni
N125	58/64/70mm	125 mm	28,5 mm	192,00 €/uni

For different sizes, please ask the manufacturer

Standard rectangular dies MX340

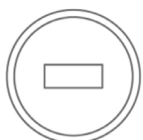
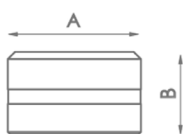

Type	Available sizes in mm	A	B	PRICE
N46	7x10/7x15/9x13/9x19/11x17/11x23 13x19/13x25/15x21mm	46 mm	28,5 mm	50,00 €/uni
N60	15x27/17x25/19x30/20x34mm	60 mm	32 mm	58,00 €/uni
N78	25x43mm	78 mm	28,5 mm	128,00 €/uni
N100	25x70mm	100 mm	28,5 mm	163,00 €/uni
N125	25x96mm	125 mm	28,5 mm	192,00 €/uni

For different sizes, please ask the manufacturer

Accessories for Hydraulic iron worker MX340G

Oval dies MX340



Type	Available sizes in mm	A	B	PRICE
N46	7x10/7x15/7x20/9x13/9x19/11x17/11x23 11x27/13x18/13x22/13x27/15x20/15x24/15x27 17x22/17x26/19x26/21x27mm	46 mm	28,5 mm	32,00 €/uni
N60	13x31/15x31/17x31/17x40/19x31 19x40/21x31/21x40mm	60 mm	32 mm	41,00 €/uni
N78	25x45/25x50mm	78 mm	28,5 mm	128,00 €/uni
N100	27x63/27x75mm	100 mm	28,5 mm	163,00 €/uni
N125	30x87/30x100mm	125 mm	28,5 mm	192,00 €/uni

For different sizes, please ask the manufacturer

Tube notching tooling MX340

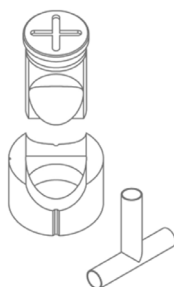

Reference	Available sizes in mm	Required fitting		PRICE
MAN28	Tube from 16 to 28mm	TAP 28	CAB 46	269,00 €/uni
MAN40	Tube from 28,5 to 40mm	TAP 40	CAB 60	340,00 €/uni
MAN50	Tube from 40,5 to 50mm	TAP 50	CAB 78	413,00 €/uni
MAN60	Tube from 50,5 to 60mm	TAP 60		498,00 €/uni

For different sizes, please ask the manufacturer

Corner rounding tooling MX340

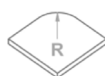

Reference	Available sizes in mm	Required fitting		PRICE
MRE28	Radius from 3 to 15mm	TAP 28	CAB 46	275,00 €/uni
MRE40	Radius from 16 to 26mm	TAP 40	CAB 60	393,00 €/uni
MRE50	Radius from 26,5 to 32mm	TAP 50	CAB 78	446,00 €/uni

For different sizes, please ask the manufacturer

Accessories for Hydraulic iron worker MX340G

Flat bar round end tooling R1 MX340

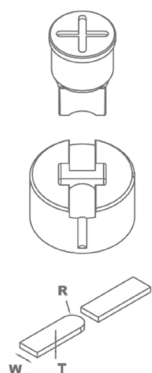

Reference	Model	Width size	Required fitting	PRICE
MOR1-35A	A	From 20 to 35mm	TAP28 / TAP40	459,00 €/uni
MOR1-35B	B	From 20 to 35mm	TAP28 / TAP40	595,00 €/uni
MOR1-35C	C	From 20 to 35mm	TAP28 / TAP40	595,00 €/uni
MOR1-35D	D	From 20 to 35mm	TAP28 / TAP40	690,00 €/uni
MOR1-50A	A	From 40 to 50mm	TAP50 / TAP60 with ATAP	495,00 €/uni
MOR1-50B	B	From 40 to 50mm	TAP50 / TAP60 with ATAP	619,00 €/uni
MOR1-50C	C	From 40 to 50mm	TAP50 / TAP60 with ATAP	619,00 €/uni
MOR1-50D	D	From 40 to 50mm	TAP50 / TAP60 with ATAP	733,00 €/uni

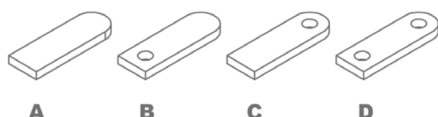

For different sizes, please ask the manufacturer.

When placing order it must be specified the REFERENCE, MODEL,

R (radius), W (flat bar width), T (flat bar thickness)

In models B, C and D specify diameter of the hole.

The ear shaped legth is always adjustable.

Production capacity: 450 to 600 parts per hour.

Flat bar round end tooling R2 MX340

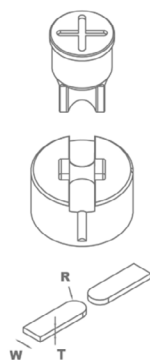

Reference	Model	Width size	Required fitting	PRICE
MOR2-35A	A	From 20 to 35mm	TAP28 / TAP40	459,00 €/uni
MOR2-35B	B	From 20 to 35mm	TAP28 / TAP40	595,00 €/uni
MOR2-35C	C	From 20 to 35mm	TAP28 / TAP40	690,00 €/uni
MOR2-50A	A	From 40 to 50mm	TAP50 / TAP60 con ATAP	495,00 €/uni
MOR2-50B	B	From 40 to 50mm	TAP50 / TAP60 con ATAP	619,00 €/uni
MOR2-50C	C	From 40 to 50mm	TAP50 / TAP60 con ATAP	733,00 €/uni

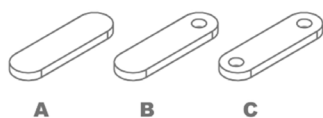

Para medidas distintas o superiores consultar con el fabricante.

Al realizar el pedido especificar REFERENCIA, MODELO, R (radio),

W (ancho pletina), T (grosor pletina)

En los modelos B y C especificar diámetro del agujero.

La longitud de la orejeta siempre es ajustable.

Capacidad de producción: 450 a 600 piezas la hora.

Accessories for Hydraulic iron worker MX340G

Angle cutting tooling. MX340

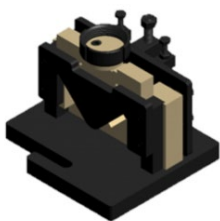

Reference: 140-02-01-00001

Angle cutting tooling, from 90° up to 45°.

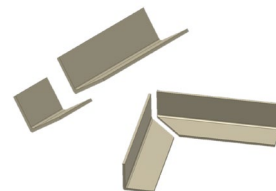

Units per machine	Max. Capacity for straight cut	Max. Cutting capacity for miter	Weight	PRICE
1	60x60mm	50x50mm	32 Kg	1.160,00 €

Flat bar cutting tooling. MX340

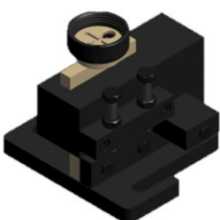

Reference: 140-02-01-00002

Tooling for cutting sheet or flat bars from 0.8mm up to 10mm thickness.

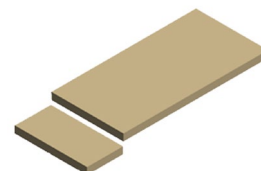

Units per machine	Max. Cutting capacity	Weight	PRICE
1	100x10mm	28 Kg	947,00 €

Folding tooling 170mm. MX340

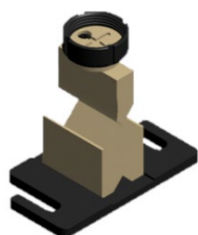

Reference: 140-02-01-00004

Tooling for folding sheet and flat bar up to 170mm. 88° punch. Dies with V for 56mm and V for 26m.

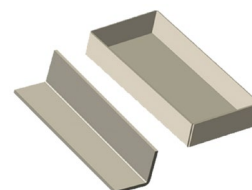

Units per machine	Max folding length	Max folding thickness	Weight	PRICE
1	170mm	8 to 12mm	12 Kg	744,00 €

Stripping tooling to 90° adjustable 100x100 MX340

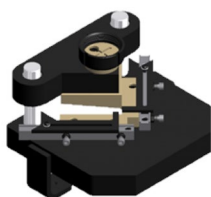

Reference: 140-02-01-00005

Stripping tooling for angle etc. Adjustable up to 100x100mm to 90° fijos.

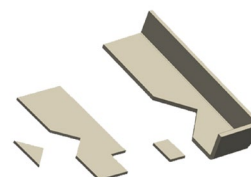

Units per machine	Max. Cutting capacity	Weight	PRICE
1	100x100x4	21 Kg	1.160,00 €

Accessories for Hydraulic iron worker MX340G

Arrow tooling for metal sheet MX340



Reference: 140-02-01-00006

Tooling for punching metal sheet in arrow shapes for fences.



Units per machine	Max. Sheet Thickness	Weight	PRICE
1	3mm	21 Kg	1.076,00 €

Arrow tooling for pipes MX340

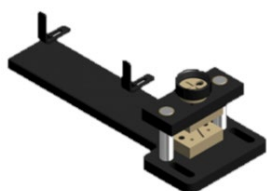

Reference: 140-02-01-00007

Tooling to flatten and cut arrow shaped pipes end. Suitable for different diameters.

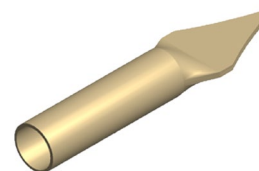

Units per machine	Pipe max. Diameter	Min. Pipe diameter	Weight	PRICE
1	30x2mm	10x2mm	19 Kg	1.011,00 €

Ventilation grip tooling. MX340

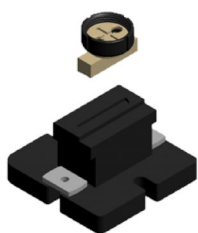

Reference: 140-02-01-00010

Tooling to make ventilation grips in metal sheet. Adjustable amount of punchings. They are to made one by one.

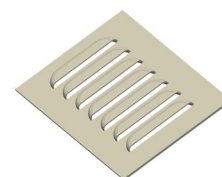

Units per machine	Punchings sizes	Max. thickness	Weight	PRICE
1	100x20mm	2mm	20Kg	891,00 €

Angle & U profile punching tooling MX340

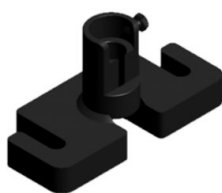

Reference: 140-02-01-00031

Base holder for angle punching. Suitable for punches and dies of different diameters, exchangeables.



Units per machine	Max. Hole diameter	Min. Hole diameter	Weight	PRICE
1	28mm	2mm	7 Kg	250,00 €

Accessories for Hydraulic iron worker MX340G

Round bar cutting tooling. MX340

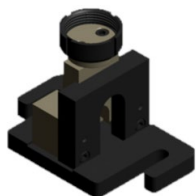

Reference: 140-02-01-00035

Tooling for cutting round bar from 3mm up to 35mm.

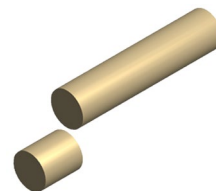

Units per machine	Max. Cutting diameter	Min. Cutting diameter	Weight	PRICE
1	35mm	3mm	15 Kg	909,00 €

Locks punch and die MX340



Reference: 140-02-01-00036

Set for making the lock hole in metal sheet.

Necessary complements: CAB60 and TAP40

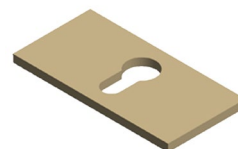

Parts per set	Max. Thickness	Weight	PRICE
2	6mm	1 Kg	231,00 €

Flattening tooling MX340



Reference: 140-02-01-00039

It's an extractor which acts as the flat bar holder at the punching time to prevent the flat bar from deformation while being punched.

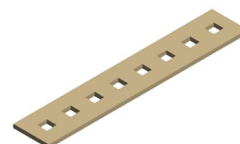

Parts per tooling	Flat Bar Max Thickness	Weight	PRICE
3	15mm	15 Kg	875,00 €

Fence post end tooling MX340

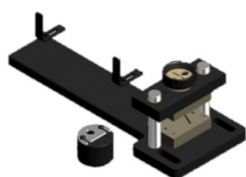

Reference: 140-02-01-00040

Tooling to flatten and punch the pipe for fences. It admits different pipe diameters. Exchangeable hole size.

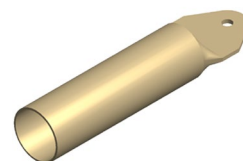

Parts per tooling	Max. Pipe diameter	Min. Pipe diameter	Hole diameter	Weight	PRICE
2	50mm	10mm	Exchangeable	23 Kg	1.058,00 €

Hydraulic iron worker

Hydraulic iron worker MX700

The Hydraulic Punching Machine MX700 Nargesa main feature is its versatility. It can make several functions as punching operations in metal sheet, flat bar, pipe, angle, U-T-UPN-IPN profiles, folding, cutting, tube notching, inlaying, punching, bending sheets, stamping... It can be suitable for any other kind of tooling.

Reference	100-02-02-003
Engine power	5,5 KW / 7,5 HP
Three-phased tension	400 V
Hydraulic power	70 Tn
Working speed	9 mm/s
Return speed	14 mm/s
Punch displacement	160 mm
Neck	350 mm
Tooling support table	600x350 mm
Dimensions	1130x1370x2060 mm
Weight	2000 Kg
PRICE	15.649,00 €



Accessories for Hydraulic iron worker MX700

Fitting nuts for punches MX700



TAP



ATAP

Reference	Type	Fitting nuts for punches	PRICE
120-02-02-00312	TAP28	Fitting nuts for punches N28 <i>Standard</i>	114,00 €
140-02-02-00011	TAP40	Fitting nuts for punches N40	114,00 €
140-02-02-00015	TAP50	Fitting nuts for punches N50	114,00 €
140-02-02-00014	TAP60	Fitting nuts for punches N60	114,00 €
140-02-02-00010	TAP75	Fitting nuts for punches N75	114,00 €
140-02-02-00012	TAP100	Fitting nuts for punches N100	114,00 €
125-02-02-00042	ATAP	Fitting part for TAP100	92,00 €

Fitting parts for dies MX700



CAB

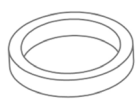

CAB N125

Reference	Type	Fitting for dies	PRICE
120-02-02-00313	N46	Fitting for dies N46 <i>Standard</i>	102,00 €
140-02-02-00019	N60	Fitting for dies N60	102,00 €
140-02-02-00028	N78	Fitting for dies N78	102,00 €
140-02-02-00044	N85	Fitting for dies N85	102,00 €
140-02-02-00029	N100	Fitting for dies N100	102,00 €
140-02-02-00027	N125	Fitting for dies N125	60,00 €

Standard round punches MX700

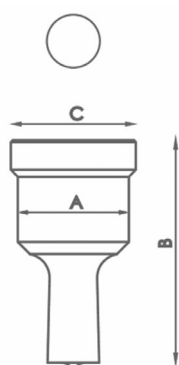

Type	Available sizes in mm Ø	A	B	C	PRICE
N28	3/3'5/4/4'5/5/5'5/6/6'5/7/7'5/8 8'5 /9mm up to 28mm from 0'5 in 0'5mm	28 mm	58 mm	31,5 mm	22,00 €/uni
N40	29/30/31/32/33/34/35 36/37/38/39/40mm	40 mm	64 mm	43,5 mm	32,00 €/uni
N50	41/42/43/44/45/46/47/48/49/50mm	50 mm	58 mm	54 mm	105,00 €/uni
N60	52/54/56/58/60mm	60 mm	58 mm	64 mm	112,00 €/uni
N75	62/64/66/68/70/72/74mm	75 mm	58 mm	79 mm	112,00 €/uni
N100	76/78/80/82/84/86/88 90/92/94/96/98/100mm	100 mm	58 mm	104 mm	169,00 €/uni

For different sizes, please ask the manufacturer

Accessories for Hydraulic iron worker MX700

Standard square punches MX700

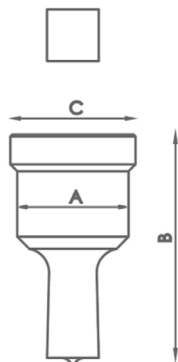

Type	Available sizes in mm	A	B	C	PRICE
N28	4/5/6/7/8/9/10/11/12/13/14/15 16/17/18/19/20mm	28 mm	58 mm	31,5 mm	42,00 €/uni
N40	21/22/24/26/28mm	40 mm	64 mm	43,5 mm	73,00 €/uni
N50	31/33/35mm	50 mm	58 mm	54 mm	135,00 €/uni
N75	40/44/48/53mm	75 mm	58 mm	79 mm	158,00 €/uni
N100	58/64/70mm	100 mm	58 mm	104 mm	200,00 €/uni

For different sizes, please ask the manufacturer

Standard rectangular punches MX700

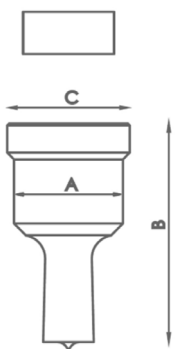

Type	Available sizes in mm	A	B	C	PRICE
N28	7x10/7x15/9x13/9x19/11x17/11x23 13x19/15x21mm	28 mm	58 mm	31,5 mm	42,00 €/uni
N40	13x25/15x27/17x25/19x30/20x34mm	40 mm	64 mm	43,5 mm	73,00 €/uni
N50	25x43mm	50 mm	58 mm	54 mm	135,00 €/uni
N75	25x70mm	75 mm	58 mm	79 mm	158,00 €/uni
N100	25x96mm	100 mm	58 mm	104 mm	200,00 €/uni

For different sizes, please ask the manufacturer

Standard oval punches MX700

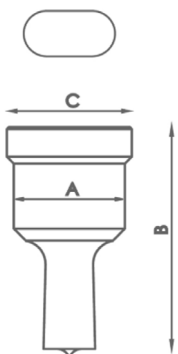

Type	Available sizes in mm	A	B	C	PRICE
N28	7x10/7x15/7x20/9x13/9x19/11x17/11x23 11x27/13x18/13x22/13x27/15x20/15x24 15x27/17x22/17x26/19x26/21x27mm	28 mm	58 mm	31,5 mm	42,00 €/uni
N40	13x31/15x31/17x31/17x40/19x31 19x40/21x31/21x40mm	40 mm	64 mm	43,5 mm	73,00 €/uni
N50	25x45/25x50mm	50 mm	58 mm	54 mm	135,00 €/uni
N75	27x63/27x75mm	75 mm	58 mm	79 mm	159,00 €/uni
N100	30x87/30x100mm	100 mm	58 mm	104 mm	199,00 €/uni

For different sizes, please ask the manufacturer

Accessories for Hydraulic iron worker MX700

Standard round dies MX700

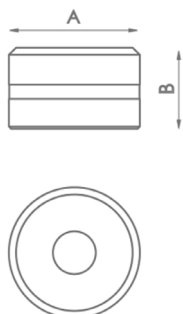

Type	Available sizes in mm	A	B	PRICE
N46	3/3,5/4/4,5/5/5,5/6/6,5/7/7,5/8/8,5 9mm up to 28mm from 0,5 in 0,5mm	46 mm	28,5 mm	17,00 €/uni
N60	29/30/31/32/33/34/35/36/37/38/39/40mm	60 mm	32 mm	21,00 €/uni
N78	41/42/43/44/45/46/47/48/49/50mm	78 mm	28,5 mm	86,00 €/uni
N100	52/54/56/58/60/62/64/66/68/70/72/74mm	100 mm	28,5 mm	113,00 €/uni
N125	76/78/80/82/84/86/88/90/92/94/96/98/100mm	125 mm	28,5 mm	132,00 €/uni

For different sizes, please ask the manufacturer

Standard square dies MX700

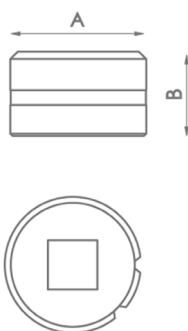

Type	Available sizes in mm	A	B	PRICE
N46	4/5/6/7/8/9/10/11/12/13/14/15/16/17/18/19/20mm	46 mm	28,5 mm	50,00 €/uni
N60	21/22/24/26/28mm	60 mm	32 mm	58,00 €/uni
N78	31/33/35mm	78 mm	28,5 mm	128,00 €/uni
N100	40/44/48/53mm	100 mm	28,5 mm	163,00 €/uni
N125	58/64/70mm	125 mm	28,5 mm	192,00 €/uni

For different sizes, please ask the manufacturer

Standard rectangular dies MX700

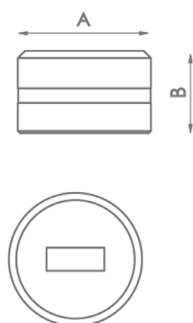

Type	Available sizes in mm	A	B	PRICE
N46	7x10/7x15/9x13/9x19/11x17/11x23 13x19/13x25/15x21mm	46 mm	28,5 mm	50,00 €/uni
N60	15x27/17x25/19x30/20x34mm	60 mm	32 mm	58,00 €/uni
N78	25x43mm	78 mm	28,5 mm	128,00 €/uni
N100	25x70mm	100 mm	28,5 mm	163,00 €/uni
N125	25x96mm	125 mm	28,5 mm	192,00 €/uni

For different sizes, please ask the manufacturer

Accessories for Hydraulic iron worker MX700

Oval dies MX700



Type	Available sizes in mm	A	B	PRICE
N46	7x10/7x15/7x20/9x13/9x19/11x17/11x23 11x27/13x18/13x22/13x27/15x20/15x24/15x27 17x22/17x26/19x26/21x27mm	46 mm	28,5 mm	32,00 €/uni
N60	13x31/15x31/17x31/17x40/19x31 19x40/21x31/21x40mm	60 mm	32 mm	41,00 €/uni
N78	25x45/25x50mm	78 mm	28,5 mm	128,00 €/uni
N100	27x63/27x75mm	100 mm	28,5 mm	163,00 €/uni
N125	30x87/30x100mm	125 mm	28,5 mm	192,00 €/uni

For different sizes, please ask the manufacturer

Tube notching tooling MX700

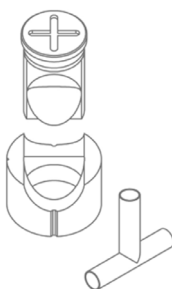

Reference	Available sizes in mm	Required fitting		PRICE
MAN28	Tube from 16 to 28mm	TAP 28	CAB 46	269,00 €/uni
MAN40	Tube from 28,5 to 40mm	TAP 40	CAB 60	340,00 €/uni
MAN50	Tube from 40,5 to 50mm	TAP 50	CAB 78	413,00 €/uni
MAN60	Tube from 50,5 to 60mm	TAP 60		498,00 €/uni

For different sizes, please ask the manufacturer

Corner rounding tooling MX



Reference	Available sizes in mm	Required fitting		PRICE
MRE28	Radius from 3 to 15mm	TAP 28	CAB 46	275,00 €/uni
MRE40	Radius from 16 to 26mm	TAP 40	CAB 60	393,00 €/uni
MRE50	Radius from 26,5 to 32mm	TAP 50	CAB 78	446,00 €/uni

For different sizes, please ask the manufacturer

Accessories for Hydraulic iron worker MX700

Flat bar round end tooling R1 MX700

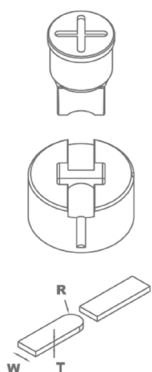

Reference	Model	Width size	Required fitting	PRICE
MOR1-35A	A	From 20 to 35mm	TAP28 / TAP40	459,00 €/uni
MOR1-35B	B	From 20 to 35mm	TAP28 / TAP40	595,00 €/uni
MOR1-35C	C	From 20 to 35mm	TAP28 / TAP40	595,00 €/uni
MOR1-35D	D	From 20 to 35mm	TAP28 / TAP40	690,00 €/uni
MOR1-50A	A	From 40 to 50mm	TAP50 / TAP60 with ATAP	495,00 €/uni
MOR1-50B	B	From 40 to 50mm	TAP50 / TAP60 with ATAP	619,00 €/uni
MOR1-50C	C	From 40 to 50mm	TAP50 / TAP60 with ATAP	619,00 €/uni
MOR1-50D	D	From 40 to 50mm	TAP50 / TAP60 with ATAP	733,00 €/uni

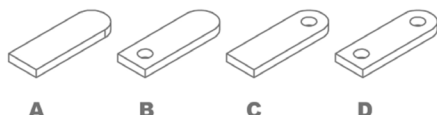

For different sizes, please ask the manufacturer.

When placing order it must be specified the REFERENCE, MODEL,

R (radius), W (flat bar width), T (flat bar thickness)

In models B, C and D specify diameter of the hole.

The ear shaped legth is always adjustable.

Production capacity: 450 to 600 parts per hour.

Flat bar round end tooling R2 MX700

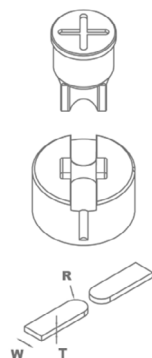

Reference	Model	Width size	Required fitting	PRICE
MOR2-35A	A	From 20 to 35mm	TAP28 / TAP40	459,00 €/uni
MOR2-35B	B	From 20 to 35mm	TAP28 / TAP40	595,00 €/uni
MOR2-35C	C	From 20 to 35mm	TAP28 / TAP40	690,00 €/uni
MOR2-50A	A	From 40 to 50mm	TAP50 / TAP60 con ATAP	495,00 €/uni
MOR2-50B	B	From 40 to 50mm	TAP50 / TAP60 con ATAP	619,00 €/uni
MOR2-50C	C	From 40 to 50mm	TAP50 / TAP60 con ATAP	733,00 €/uni

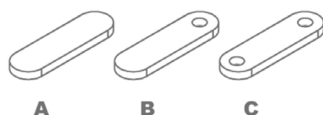

For different sizes, please ask the manufacturer.

When placing order it must be specified the REFERENCE, MODEL, R (radius),

W (flat bar width), T (flat bar thickness)

In models B and C specify hole diameter.

The ear shaped legth is always adjustable.

Production capacity: 450 to 600 parts per hour.

Accessories for Hydraulic iron worker MX700

Ventilation grip tooling MX700

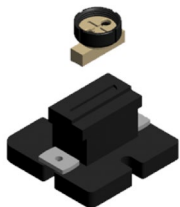

Reference: 140-02-02-00031

Tooling to make ventilation grips in metal sheet.
Adjustable amount of punchings which are to be made one by one.

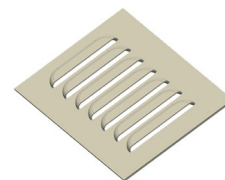

Units per machine	Punchings sizes	Max. thickness	Weight	PRICE
1	100x20mm	2mm	21Kg	947,00 €

Locks punch and die MX700



Reference: 140-02-01-00036

Set of punch and die to make the locks punching in metal sheet.
Necessary complements: CAB60 and TAP40



Pieces per set	Max. Thickness	Weight	PRICE
2	6mm	1 Kg	231,00 €

Stripping tooling 90° adjustable 150x150 MX700

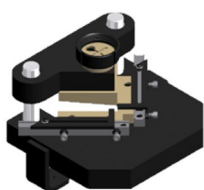

Reference: 140-02-02-00001

Stripping tooling for metal sheet, angle... Adjustable up to 150x150mm to 90° fixed.

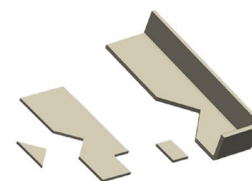

Units per machine	Max. Cutting capacity	Weight	PRICE
1	150x150x8mm	38 Kg	1.780,00 €

Flat bar cutting tooling 200 x 20. MX700

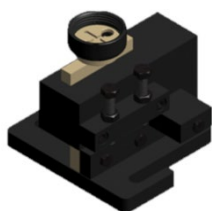

Reference: 140-02-02-00002

Tooling for cutting flat bar or metal sheet from 0.8mm up to 20mm Thickness.

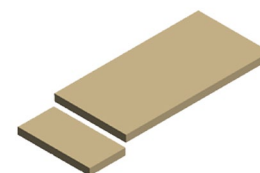

Units per machine	Max. Cutting capacity	Weight	PRICE
1	200x20mm	54 Kg	1.780,00 €

Accessories for Hydraulic iron worker MX700

Angle and U profile punching machine MX700

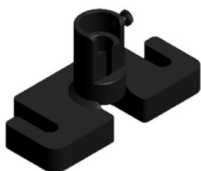

Reference: 140-02-01-00031

Base holder for punching angles. The punches and dies of different diameters are exchangeable.



Units per machine	Max. Hole Diameter	Min. Hole Diameter	Weight	PRICE
1	28mm	2mm	7 Kg	250,00 €

Folding tooling 170mm. MX700



Reference: 140-02-02-00034

Tooling for folding sheet and flat bar up to 170mm. 88° punch. Dies with V for 56mm and V for 26m.

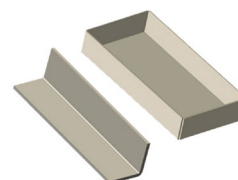

Units per machine	Max. Folding Length	Max. Folding Thickness	Weight	PRICE
1	170mm	8 to 12mm	13 Kg	803,00 €

Angle cutting tooling. MX700

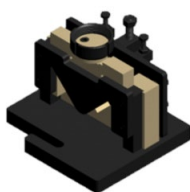

Reference: 140-02-02-00036

Tooling for cutting angles from 90° up to 45°.

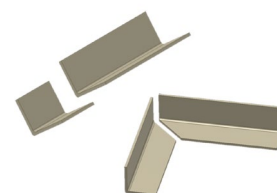

Units per machine	Max cutting capacity Straight cut	Max. Cutting capacity Miter cut	Weight	PRICE
1	80x80mm	50x50mm	32 Kg	1.235,00 €

Flat bar cutting tooling 100 x 12. MX700



Reference: 140-02-02-00037

Tooling for cutting metal sheet or flat bar from 0.8mm up to 12mm thickness.

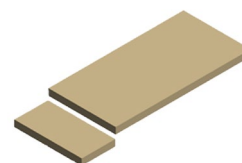

Units per machine	Max. Cutting capacity	Weight	PRICE
1	100x12mm	29 Kg	974,00 €



Accessories for Hydraulic iron worker MX700

Round bar cutting tooling MX700

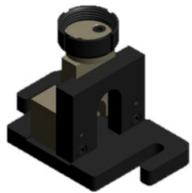

Reference: 140-02-02-00038

Tooling for cutting round bar from 3mm up to 35mm.

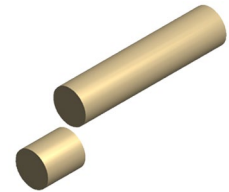

Units per machine	Max. Cutting diameter	Min. Cutting diameter	Weight	PRICE
1	35mm	3mm	16 Kg	937,00 €

Fence post end tooling MX700

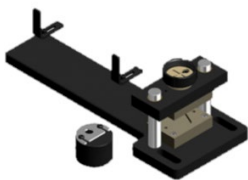

Reference: 140-02-02-00039

Tooling to flatten and punch the pipe for fences. It admits different pipe diameters. Exchangeable hole size.

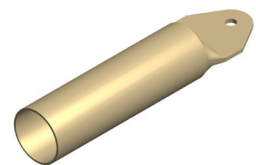

Pieces by tooling	Pipe Max. Diameter	Pipe Min. Diameter	Hole Diameter	Weight	PRICE
2	50mm	10mm	Exchangeable	24 Kg	1.086,00 €

Arrow tooling for pipes MX700

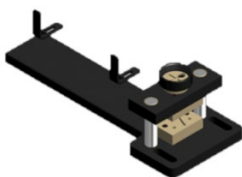

Reference: 140-02-02-00040

Tooling for flattening and cutting pipes in arrow sha-pes. Suitable for different diameters.

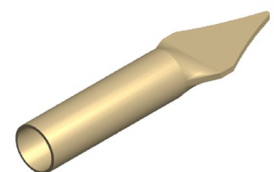

Units per machine	Pipe Max. Diameter	Pipe Min. Diameter	Weight	PRICE
1	30x2mm	10x2mm	20 Kg	1.043,00 €

Arrow tooling for metal sheet MX700

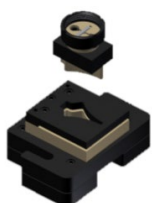

Reference: 140-02-02-00041

Tooling for punching metal sheet in arrow shapes for fences.



Units per machine	Sheet Max. Thickness	Weight	PRICE
1	3mm	22 Kg	1.101,00 €

Accessories for Hydraulic iron worker MX700

Flattening tooling MX700



Reference: 140-02-02-00042

It's an extractor which acts as the flat bar holder at the punching time to prevent the flat bar from deformation while being punched.

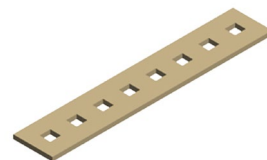

Pieces per tooling	Bar or flat bar max. thickness	Weight	PRICE
1	15mm	15 Kg	803,00 €

Folding tooling 350mm. MX700

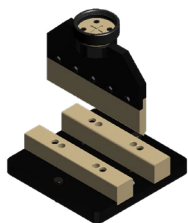

Reference: 140-02-02-00043

Tooling to fold metal sheet and flat bar up to 350mm.
Punch: 88°. Die with adjustable V of 120mm, 80mm, 40mm and 16mm.

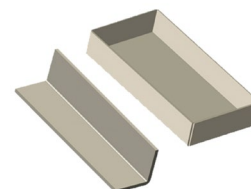

Units per machine	Max. Folding Length	Max. Folding Thicknesss	Weight	PRICE
1	350mm	20mm	45 Kg	1.230,00 €

Profile Formers

Profile former MC150B

Section bending, pipe curving machine MC150B Nargesa. Our pipe bender MC150B is designed to minimize the manufacturing cost and provide maximum performance when bending pipes and profiles. It has been manufactured for different profiles such as flat bar or bar section, T-profile, rolling U-profile, bending angle, bending solid rod, both square and round types, spiral tube or even to perform square, rectangular or round pipe.

Reference	100-08-07-001
Engine power	0,75 KW / 1 HP
Tension Single-phase	230 V
Speed	6 r.p.m.
Axes diameter	40 mm
Rollers diameter	127 mm
Useful axes length	74 mm
Dimensions	680x950x1240 mm
Weight	270 Kg
PRICE	5.155,00 €



Profile former MC200

Profile former MC200 Nargesa, is made of mechanized and weldes Steel sheet. Unlike others, this one's not made of melting. It has been conceived for work pipes and profiles. It is ideal for making spiral stairs, to bend pipes in spiral shapes, flanges for pipes, greenhouses, handrails, tables, chairs, doors, windows... making all kind of circular shapes in all kinds of profiles.

Reference	100-08-02-002
Engine power	1,1 KW / 1,5 HP
Tension 3-phased	230 / 400 V
Speed	8 r.p.m.
Axes diameter	40 mm
Rollers diameter	127 mm
Useful axes length	74 mm
Dimensions	790x810x1300 mm
Weight	320 Kg
PRICE	6.439,00 €



Profile Formers

Profile former MC400

Profile former MC400 Nargesa, is made of mechanized and welded Steel sheet. Unlike others, this one's not made of melting. It has been conceived for work pipes and profiles. It is ideal for making spiral stairs, to bend pipes in spiral shapes, flanges for pipes, greenhouses, handrails, tables, chairs, doors, windows... making all kind of circular shapes in all kinds of profiles.

Reference	100-08-01-001
Engine power	1,1 KW / 1,5 HP
Tension 3-phased	230 / 400 V
Speed	7 r.p.m.
Axes diameter	40 mm
Rollers diameter	130 mm
Useful axes length	80 mm
Dimensions	660x760x1250 mm
Weight	365 Kg
PRICE	7.967,00 €



Profile former MC200H

Profile Former MC200H Nargesa, made of welded and mechanized steel sheet. Unlike the others, this one is not made of cast iron. Ideal for making flanges, greenhouses, balustrades, tables, chairs, doors, windows... making a great number of circular shape in all kinds of profiles. Its robustness, axis diameter, reducer capacity and other features, make it one of the best bending machines in the market, within the category of two traction rollers.

Reference	100-08-03-001
Engine power	1,85 KW / 2,5 HP
Tension 3-phased	230 / 400 V
Speed	8 r.p.m.
Axes diameter	40 mm
Rollers diameter	127 mm
Useful axes length	74 mm
Dimensions	790x810x1540 mm
Weight	360 Kg
PRICE	9.428,00 €



Accessories for Profile formers MC150B, MC200, MC200H and MC400

Set of treated steel rollers · MC150B · MC200 · MC200H · MC400



Set of 3 treated steel rollers for steel round pipe or stainless steel, thickness bigger than 2 mm.

When pipe sizes are smaller, two sizes are included in the same roller.

Eg. (25 + 30) o (1/2" + 1"1/4")

Always clean up the rollers well before using stainless steel not to get the pipe contaminated.

Tube size in mm			
Reference	Dimensions	Weight	PRICE
140-08-01-RHT0007	(25 + 30)	17,00 Kg.	568,00 €
140-08-01-RHT0006	(20 + 35)	16,50 Kg.	568,00 €
140-08-01-RHT0001	40	16,60 Kg.	568,00 €
140-08-01-RHT0002	50	14,25 Kg.	568,00 €
140-08-01-RHT0003	60	11,10 Kg.	568,00 €
For Schedule pipe			
140-08-01-RHISOT0006	(3/4" + 1/2") = (26,9 + 21,3 mm)	17,70 Kg.	568,00 €
140-08-01-RHISOT0007	(1" + 3/8") = (33,7 + 17,2 mm)	17,00 Kg.	568,00 €
140-08-01-RHISOT0002	1" 1/4 = 42,4 mm	16,00 Kg.	568,00 €
140-08-01-RHISOT0003	1" 1/2 = 48,3 mm	14,40 Kg.	568,00 €
140-08-01-RHISOT0004	2" = 60,3 mm	11,15 Kg.	568,00 €
For inches pipe			
140-08-01-RHWT-00001	(1/2"+1"1/4) = (12,700 + 31,751 mm)	18,00 Kg.	568,00 €
140-08-01-RHWT-00002	(1"+3/4") = (25,401 + 19,051 mm)	18,50 Kg.	568,00 €
140-08-01-RHWT-00003	1"1/2 = 38,101 mm	17,25 Kg.	568,00 €
140-08-01-RHWT-00004	2" = 50,802 mm	13,60 Kg.	568,00 €
140-08-01-RHWT-00005	2"1/2 = 63,502 mm	9,75 Kg.	568,00 €

Accessories for Profile formers MC150B, MC200, MC200H and MC400

Set of Sustarín rollers · MC150B · MC200 · MC200H · MC400



Set of 3 Sustarin rollers for stainless steel pipes, aluminium and delicate materials for thickness smaller than 2.5 mm.

When pipe sizes are smaller, two sizes are included in the same roller. Eg. (25 + 30)

Sustarin rollers do not spoil or contaminate the pipe.

For any other size or profile please ask the manufacturer.

Tube size in mm			
Reference	Dimensions	Weight	PRICE
140-08-01-RI0007	(25 + 30)	1,40 Kg.	402,00 €
140-08-01-RI0001	(20 + 35)	1,40 Kg.	402,00 €
140-08-01-RI0010	33	1,50 Kg.	402,00 €
140-08-01-RI0004	40	1,40 Kg.	402,00 €
140-08-01-RI0003	43	1,30 Kg.	402,00 €
140-08-01-RI0006	50	1,20 KG.	402,00 €
140-08-01-RI0008	60	0,90 KG.	402,00 €
For Schedule inches			
140-08-01-RIISO0001	$(3/4" + 1/2") = (26,9 + 21,3 \text{ mm})$	1,70 Kg.	402,00 €
140-08-01-RIISO0002	$(1" + 3/8") = (33,7 + 17,2 \text{ mm})$	1,60 Kg.	402,00 €
140-08-01-RIISO0003	$1" 1/4 = 42,4 \text{ mm}$	1,30 Kg.	402,00 €
140-08-01-RIISO0004	$1" 1/2 = 48,3 \text{ mm}$	1,20 Kg.	402,00 €
140-08-01-RIISO0005	$2" = 60,3 \text{ mm}$	0,90 Kg.	402,00 €
For inches pipe			
140-08-01-RIW-00001	$(1/2" + 1" 1/4) = (12,700 + 31,751 \text{ mm})$	1,80 Kg.	402,00 €
140-08-01-RIW-00002	$(1" + 3/4") = (25,401 + 19,051 \text{ mm})$	1,50 Kg.	402,00 €
140-08-01-RIW-00003	$1" 1/2 = 38,101 \text{ mm}$	1,40 Kg.	402,00 €
140-08-01-RIW-00004	$2" = 50,802 \text{ mm}$	1,20 Kg.	402,00 €
140-08-01-RIW-00005	$2" 1/2 = 63,502 \text{ mm}$	0,90 Kg.	402,00 €

Profile formers

Profile formers MC550

The NEW MC550 Nargesa Section and pipe bending machine is specially designed to carry out mass production through the control, which saves the position of the rollers in each curve to repeat the same operations later, without longitudinal positioning control. It is ideal for manufacturing flanges, greenhouses, railings, large structures for construction... **Maximum capacity for bending round pipe: 3" inches (76,2 mm) or 80 mm.** Its robustness, axis diameter, reduction capacity, Control Panel and 4.0 Technology make out of it one of the best bending machines on the market in the **three-driven roller category, an essential condition for working tubes and large profiles with a perfect finish.**

Reference	100-08-13-001
Engine power	1,5 Kw / 2 HP
Hydraulic motor power	0,75 Kw / 1 HP
Tension Single-phase	220 V
Adjustable roller speed	From 3 to 8 RPM.
Axes diameter	50 mm or 2"
Useful axes length	90 mm or 3,5"
Dimensions	965x1190x1341 mm
Weight	840 Kg
PRICE	16.900,00 €



Nargesa MC550 pipe benders are controlled with a very intuitive and easy-to-use 7" color touchscreen with the latest 4.0 technology. **You only need to do the first piece and save each step so that the control will repeat the same operations on the other pieces in the same series automatically,** without longitudinal positioning control.

You can add the type and dimensions of the pipe or profile, the material and position of the rollers to the program so all of this is saved for the following series.

Accessories for Profile formers MC550

CNC Bending Kit

Reference: 140-08-13-01000

PRICE: 5.699,00 €

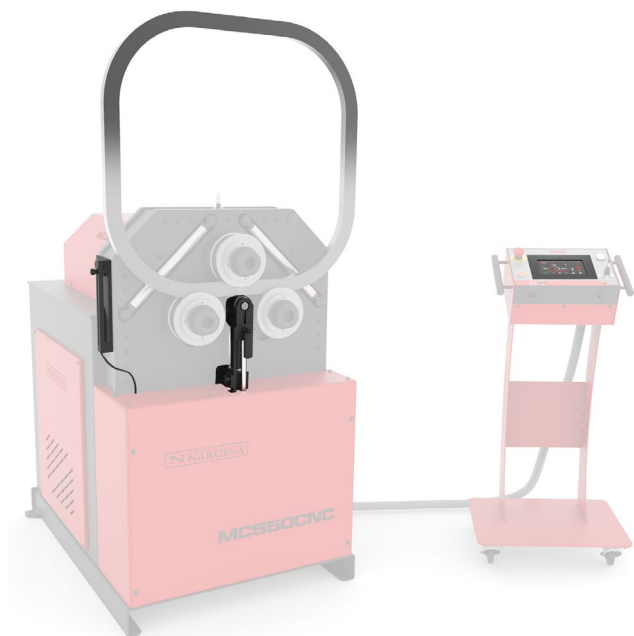

Packaging

Dimensions: 840 x 720 x 260 mm

Weight: 28,5 Kg.

The ALL-NEW CNC bending kit is the ideal accessory designed and manufactured to get the most out of Nargesa MC550 pipe and profile benders. This kit can be installed whenever the customer wants; in other words, some time after having purchased the bending machine.

Its incredible smart predictive system, which is being offered for the first time ever in the world's tube and profile bending industry, guarantees any desired radius right away. Unbeatable ease of programming for operators, speed and reliability for unique pieces and large series. The CNC bending kit minimizes material waste, increases productivity and speeds up the creation of complex pieces. It offers exceptional repetitiveness, a simple, intuitive and powerful interface with CNC ESA S820 control, absolute connectivity for industry 4.0, safety, durability and maximum efficiency.

The interpolated axle control and independent speed management guarantee excellent results and soft transitions, which leads to greater and better productivity with perfect mass-produced pieces and exceptional repetitiveness.

- **Absolute positioning control:** With a high-resolution 4096 impulse encoder, quadrature decoder, A+B channels, 5 Vdc, DB9 connector.
- **Smart predictive system:** Developed exclusively by Nargesa and built into a CNC ESA S820 control, it helps obtain the desired radius right away which minimizes material waste and speeds up the process of creating complex pieces.
- **Easy to program:** Anyone with minimal knowledge can bend highly complex pieces. > **Repetitiveness:** Guarantees the creation of identical pieces with minimal tolerances.
- **Varied bending speed:** The speed can be adjusted irrespective of the bending operation or material to be bent.
- **Perfect pieces with soft transitions:** Thanks to the interpolated axle control with independent speed adjustment during bending.
- **CNC bending software:** Gets radiuses right away, axle interpolation, bend direction configuration, soft transitions, step-by-step, digital mode.
- **Photocell:** 300 mm long-range direct reflection, PNP NO output, M12 connector.
- **Gas spring:** 200 newton release speed, lock knob, guided by linear sliding bearings, rotating and bendable handle.
- **Maximum speed:** Up to 70 mm/s
- **Completely automatic bending:** Control button with an indicator light.
- **Material savings:** Up to 90% less material waste.

Profile formers

Profile formers MC550CNC

The all-new Nargesa MC550CNC CNC pipe and profile bending machine was designed for single pieces as well as mass production. Its advanced CNC control panel makes it possible to easily create any desired geometry by directly programming the radiuses required to obtain mass-produced pieces with exceptional repetitiveness. Built with welded and machined steel sheet, the MC550CNC stands out due to its resistance and stability, perfectly adapting to applications such as the manufacture of clamps, greenhouses, railings, pergolas, windows, tables... It's also perfect for creating urban furniture, such as streetlamps, bike racks and public transport shelters.

Reference	100-08-14-001
Engine power	1,5 kW / 2 CV
Hydraulic motor power	0,75 kW / 1 CV
Tension Single-phase	220 V
Adjustable roller speed	From 3 to 8 RPM
Axes diameter	50 mm or 2"
Useful axes length	90 mm or 3,5"
Dimensions	965x1190x1341 mm
Weight	883 Kg
PRICE	22.080,00 €



NEW



The CNC ESA S820 control panel which comes standard with the Nargesa MC550CNC CNC pipe bender features total connectivity to comply with the requirements of the industry 4.0 as well as a 7 inch color touchscreen, which combines processing power with an intuitive, easy-to-use graphic interface. **With step-by-step digital programming modes, creating a unique piece or large series based on the initial concept is super fast and easy: define the type of tube or profile, the dimensions, the material and the axle roller configuration, and then ask the control for the desired radiuses. After that, you just have to press a button to get excellent results.**

Accessories for Profile formers MC550 and MC550CNC

Set of treated steel rollers MC550



Set of 3 treated steel rollers for steel round pipe or stainless steel, thickness bigger than 2 mm.

When pipe sizes are smaller, two sizes are included in the same roller.

Eg. (25 + 30) o (1/2" + 1"1/4")

Always clean up the rollers well before using stainless steel not to get the pipe contaminated.

Tube size in mm			
Reference	Dimensions	Weight	PRICE
140-08-13-RHT0001	(25 + 30)	40,04 Kg.	829,00 €
140-08-13-RHT0002	(20 + 35)	39,65 Kg.	829,00 €
140-08-13-RHT0003	40	39,93 Kg.	829,00 €
140-08-13-RHT0004	50	36,24 Kg.	829,00 €
140-08-13-RHT0005	60	31,92 Kg.	829,00 €
140-08-13-RHT0006	70	28,57 Kg.	829,00 €
140-08-13-RHT0007	80	23,22 Kg.	829,00 €
For Schedule pipe			
140-08-13-RHISOT0001	(3/8" + 1/2") = (17,2 + 21,3 mm)	43,53 Kg.	829,00 €
140-08-13-RHISOT0002	(1" + 3/4") = (33,7 + 26,9 mm)	38,57 Kg.	829,00 €
140-08-13-RHISOT0003	1" 1/4 = 42,4 mm	39,11 Kg.	829,00 €
140-08-13-RHISOT0004	1" 1/2 = 48,3 mm	36,91 Kg.	829,00 €
140-08-13-RHISOT0005	2" = 60,3 mm	31,77 Kg.	829,00 €
140-08-13-RHISOT0006	2" 1/2 = 73 mm	27,01 Kg.	829,00 €
For inches pipe			
140-08-13-RHWT0001	(1/2" + 1"1/4) = (12,70 + 31,75 mm)	41,67 Kg.	829,00 €
140-08-13-RHWT0002	(1" + 3/4") = (25,40 + 19,05 mm)	42,35 Kg.	829,00 €
140-08-13-RHWT0003	1" 1/2 = 38,1 mm	40,56 Kg.	829,00 €
140-08-13-RHWT0004	2" = 50,8 mm	35,92 Kg.	829,00 €
140-08-13-RHWT0005	2" 1/2 = 63,5 mm	30,28 Kg.	829,00 €
140-08-13-RHWT0006	3" = 76,2 mm	25,31 Kg.	829,00 €

Accessories for Profile formers MC550 and MC550CNC

Set of Sustarín rollers MC550



Set of 3 Sustarin rollers for stainless steel pipes, aluminium and delicate materials for thickness smaller than 2.5 mm.

When pipe sizes are smaller, two sizes are included in the same roller. Eg. (25 + 30)

Sustarin rollers do not spoil or contaminate the pipe.

For any other size or profile please ask the manufacturer.

Tube size in mm			
Reference	Dimensions	Weight	PRICE
140-08-13-RI0001	(25 + 30)	7,24 Kg.	722,00 €
140-08-13-RI0002	(20 + 35)	7,17 Kg.	722,00 €
140-08-13-RI0003	40	7,22 Kg.	722,00 €
140-08-13-RI0004	50	6,55 Kg.	722,00 €
140-08-13-RI0005	60	5,77 Kg.	722,00 €
140-08-13-RI0006	70	5,17 Kg.	722,00 €
140-08-13-RI0007	80	4,20 Kg.	722,00 €
For Schedule pipe			
140-08-13-RIISO0001	$(3/8" + 1/2") = (17,2 + 21,3 \text{ mm})$	7,87 Kg.	722,00 €
140-08-13-RIISO0002	$(1" + 3/4") = (33,7 + 26,9 \text{ mm})$	6,98 Kg.	722,00 €
140-08-13-RIISO0003	$1" 1/4 = 42,4 \text{ mm}$	7,07 Kg.	722,00 €
140-08-13-RIISO0004	$1" 1/2 = 48,3 \text{ mm}$	6,68 Kg.	722,00 €
140-08-13-RIISO0005	$2" = 60,3 \text{ mm}$	5,75 Kg.	722,00 €
140-08-13-RIISO0006	$2" 1/2 = 73 \text{ mm}$	4,89 Kg.	722,00 €
For inches pipe			
140-08-13-RIWT0001	$(1/2" + 1" 1/4) = (12,70 + 31,75 \text{ mm})$	7,54 Kg.	722,00 €
140-08-13-RIWT0002	$(1" + 3/4") = (25,40 + 19,05 \text{ mm})$	7,66 Kg.	722,00 €
140-08-13-RIWT0003	$1" 1/2 = 38,1 \text{ mm}$	7,33 Kg.	722,00 €
140-08-13-RIWT0004	$2" = 50,8 \text{ mm}$	6,50 Kg.	722,00 €
140-08-13-RIWT0005	$2" 1/2 = 63,5 \text{ mm}$	5,47 Kg.	722,00 €
140-08-13-RIWT0006	$3" = 76,2 \text{ mm}$	4,58 Kg.	722,00 €

Profile formers

Profile formers MC650

The NEW MC650 Nargesa Section and pipe bending machine is specially designed to carry out mass production through the control, which saves the position of the rollers in each curve to repeat the same operations later, without longitudinal positioning control. It is ideal for manufacturing flanges, greenhouses, railings, large structures for construction... **Maximum capacity for bending round pipe: 4" inches or 101,6 mm.**

Its robustness, axis diameter, reduction capacity, Control Panel and 4.0 Technology make out of it one of the best bending machines on the market in the **three-driven roller category, an essential condition for working tubes and large profiles with a perfect finish.**

Reference	100-08-08-001
Engine power	3 Kw / 4 HP
Hydraulic motor power	0,75 Kw / 1 CV
Tension 3-phased	230/400 V
Adjustable roller speed	From 3 to 8 RPM
Axes diameter	Lower 65 mm or 2,56" Higher 80 mm or 3,15"
Useful axes length	130 mm or 5,11"
Dimensions	990x1310x1300 mm
Weight	1290 Kg
PRICE	21.900,00 €



Nargesa MC650 pipe benders are controlled with a very intuitive and easy-to-use 7" color touchscreen with the latest 4.0 technology. **You only need to do the first piece and save each step so that the control will repeat the same operations on the other pieces in the same series automatically, without longitudinal positioning control.**

You can add the type and dimensions of the pipe or profile, the material and position of the rollers to the program so all of this is saved for the following series.

Accessories for Profile formers MC650

CNC Bending Kit

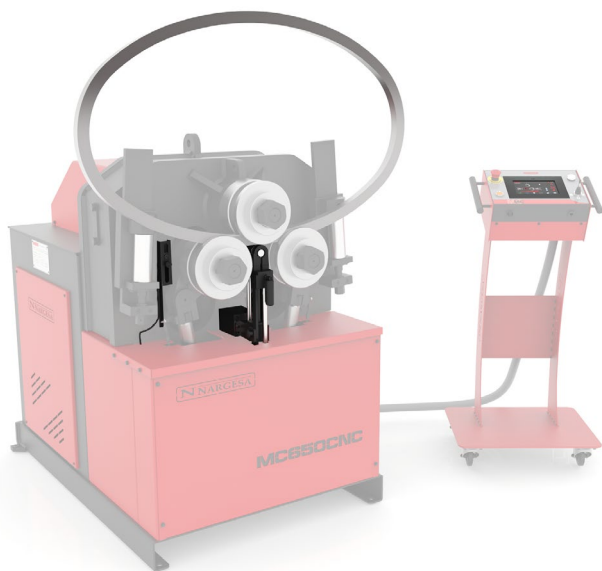

Packaging

Dimensions: 920 x 620 x 340 mm

Weight: 37 Kg.

Reference: 140-08-08-01000

PRICE: 5.699,00 €

The ALL-NEW CNC bending kit is the ideal accessory designed and manufactured to get the most out of Nargesa MC650 pipe and profile benders. This kit can be installed whenever the customer wants; in other words, some time after having purchased the bending machine.

Its incredible smart predictive system, which is being offered for the first time ever in the world's tube and profile bending industry, guarantees any desired radius right away. Unbeatable ease of programming for operators, speed and reliability for unique pieces and large series. The CNC bending kit minimizes material waste, increases productivity and speeds up the creation of complex pieces. It offers exceptional repetitiveness, a simple, intuitive and powerful interface with CNC ESA S625 control, absolute connectivity for industry 4.0, safety, durability and maximum efficiency.

The interpolated axle control and independent speed management guarantee excellent results and soft transitions, which leads to greater and better productivity with perfect mass-produced pieces and exceptional repetitiveness.

- **Absolute positioning control:** With a high-resolution 4096 impulse encoder, quadrature decoder, A+B channels, 5 Vdc, DB9 connector.
- **Smart predictive system:** Developed exclusively by Nargesa and built into a CNC ESA S625 control, it helps obtain the desired radius right away which minimizes material waste and speeds up the process of creating complex pieces.
- **Easy to program:** Anyone with minimal knowledge can bend highly complex pieces. > **Repetitiveness:** Guarantees the creation of identical pieces with minimal tolerances.
- **Varied bending speed:** The speed can be adjusted irrespective of the bending operation or material to be bent.
- **Perfect pieces with soft transitions:** Thanks to the interpolated axle control with independent speed adjustment during bending.
- **CNC bending software:** Gets radiuses right away, axle interpolation, bend direction configuration, soft transitions, step-by-step, digital mode.
- **Photocell:** 300 mm long-range direct reflection, PNP NO output, M12 connector.
- **Gas spring:** 200 newton release speed, lock knob, guided by linear sliding bearings, rotating and bendable handle.
- **Maximum speed:** Up to 90 mm/s
- **Completely automatic bending:** Control button with an indicator light.
- **Material savings:** Up to 90% less material waste.

Profile formers

Profile formers MC650CNC

The all-new Nargesa MC650CNC CNC pipe bender is the perfect solution for large mass production requiring maximum repetitiveness as well as the creation of unique pieces **thanks to the processing power offered by its advanced CNC control panel with a touch graphic interface**. Plus, its smart predictive system for bend adjustment makes it possible to obtain the radiuses requested right away to reduce material waste by up to 90%.

Its operating capacity and power make it the best choice for manufacturing a wide variety of industrial and structural applications.

Reference	100-08-15-001
Engine power	3 Kw / 4 CV
Hydraulic motor power	0,75 Kw / 1 CV
Tension 3-phased	230/400 V
Adjustable roller speed	From 3 to 8 r.p.m.
Axes diameter	Lower 65 mm or 2,56" Higher 80 mm or 3,15"
Useful axes length	130 mm or 5,11"
Dimensions	990x1310x1300 mm
Weight	1305 Kg
PRICE	27.002,00 €



NEW



The CNC ESA S625 control panel which comes standard with the Nargesa MC650CNC CNC pipe bender features total connectivity to comply with the requirements of the industry 4.0 as well as a 7 inch color touchscreen, which combines processing power with an intuitive, easy-to-use graphic interface. **With step-by-step digital programming modes, creating a unique piece or large series based on the initial concept is super fast and easy: define the type of tube or profile, the dimensions, the material and the axle roller configuration, and then ask the control for the desired radiuses. After that, you just have to press a button to get excellent results.**

Accessories for Profile formers MC650 and MC650CNC

Set of treated steel rollers MC650



Set of 3 treated steel rollers for steel round pipe or stainless steel, thickness bigger than 2 mm.

When pipe sizes are smaller, two sizes are included in the same roller.

Eg. (25 + 30) o (1/2" + 1"1/4")

Always clean up the rollers well before using stainless steel not to get the pipe contaminated.

Tube size in mm			
Reference	Dimensions	Weight	PRICE
140-08-08-RHT0001	(25 + 30)	45,30 Kg.	1.177,00 €
140-08-08-RHT0002	(20 + 35)	44,80 Kg.	1.177,00 €
140-08-08-RHT0003	40	45,30 Kg.	1.177,00 €
140-08-08-RHT0004	50	40,80 Kg.	1.177,00 €
140-08-08-RHT0005	60	35,70 Kg.	1.177,00 €
140-08-08-RHT0006	70	64,70 Kg.	1.363,00 €
140-08-08-RHT0007	80	57,40 Kg.	1.363,00 €
140-08-08-RHT0008	90	49,50 Kg.	1.363,00 €
140-08-08-RHT0009	100	41,00 Kg.	1.363,00 €
For Schedule pipe			
140-08-08-RHISOT0001	(3/8" + 1/2") = (17,2 + 21,3 mm)	49,50 Kg.	1.177,00 €
140-08-08-RHISOT0002	(1" + 3/4") = (33,7 + 26,9 mm)	43,75 Kg.	1.177,00 €
140-08-08-RHISOT0003	1" 1/4 = 42,4 mm	44,40 Kg.	1.177,00 €
140-08-08-RHISOT0004	1" 1/2 = 48,3 mm	41,60 Kg.	1.177,00 €
140-08-08-RHISOT0005	2" = 60,3 mm	35,50 Kg.	1.177,00 €
140-08-08-RHISOT0006	2" 1/2 = 73 mm	60,20 Kg.	1.363,00 €
140-08-08-RHWT0007	3" = 88,9 mm	50,35 Kg.	1.363,00 €
140-08-08-RHWT0008	3" 1/2 = 101,6 mm	39,50 Kg.	1.363,00 €
For inches pipe			
140-08-08-RHWT0001	(1/2" + 1"1/4) = (12,70 + 31,75 mm)	47,25 Kg.	1.177,00 €
140-08-08-RHWT0002	(1" + 3/4") = (25,40 + 19,05 mm)	48,00 Kg.	1.177,00 €
140-08-08-RHWT0003	1" 1/2 = 38,1 mm	45,90 Kg.	1.177,00 €
140-08-08-RHWT0004	2" = 50,8 mm	40,70 Kg.	1.177,00 €
140-08-08-RHWT0005	2" 1/2 = 63,5 mm	33,70 Kg.	1.177,00 €
140-08-08-RHWT0006	3" = 76,2 mm	60,20 Kg.	1.363,00 €
140-08-08-RHWT0007	3" 1/2 = 88,9 mm	50,35 Kg.	1.363,00 €
140-08-08-RHWT0008	4" = 101,6 mm	39,50 Kg.	1.363,00 €



Set of Steel Treated Rollers UPN-100-120mm

Set of 3 steel treated rollers for UPN mild steel or stainless steel profiles.

Always clean up the rollers well before using stainless steel not to get the pipe contaminated.

Reference	Dimensions	Weight	PRICE
140-08-08-RHT0010	Adjustable from 100 to 120mm	52,72 Kg.	2.099,00 €

Accessories for Profile formers MC650 and MC650CNC

Set of Sustarín rollers MC650



Set of 3 Sustarin rollers for stainless steel pipes, aluminium and delicate materials for thickness smaller than 2.5 mm.

When pipe sizes are smaller, two sizes are included in the same roller.

Eg. (25 + 30)

Sustarin rollers do not spoil or contaminate the pipe.

For any other size or profile please ask the manufacturer.

Tube size in mm			
Reference	Dimensions	Weight	PRICE
140-08-08-RI0001	(25 + 30)	9,35 Kg.	1.016,00 €
140-08-08-RI0002	(20 + 35)	9,25 Kg.	1.016,00 €
140-08-08-RI0003	40	9,30 Kg.	1.016,00 €
140-08-08-RI0004	50	8,50 Kg.	1.016,00 €
140-08-08-RI0005	60	7,60 Kg.	1.016,00 €
140-08-08-RI0006	70	6,50 Kg.	1.016,00 €
140-08-08-RI0007	80	11,80 Kg.	1.177,00 €
140-08-08-RI0008	90	10,35 Kg.	1.177,00 €
140-08-08-RI0009	100	8,80 Kg.	1.177,00 €
For Schedule pipe			
140-08-08-RIISOT0001	$(3/8" + 1/2") = (17,2 + 21,3 \text{ mm})$	10,10 Kg.	1.016,00 €
140-08-08-RIISOT0002	$(1" + 3/4") = (33,7 + 26,9 \text{ mm})$	9,00 Kg.	1.016,00 €
140-08-08-RIISOT0003	$1" 1/4 = 42,4 \text{ mm}$	9,15 Kg.	1.016,00 €
140-08-08-RIISOT0004	$1" 1/2 = 48,3 \text{ mm}$	8,65 Kg.	1.016,00 €
140-08-08-RIISOT0005	$2" = 60,3 \text{ mm}$	7,55 Kg.	1.016,00 €
140-08-08-RIISOT0006	$2" 1/2 = 73 \text{ mm}$	12,30 Kg.	1.177,00 €
140-08-08-RIWT0007	$3" = 88,9 \text{ mm}$	10,50 Kg.	1.177,00 €
140-08-08-RIWT0008	$3" 1/2 = 101,6 \text{ mm}$	8,50 Kg.	1.177,00 €
For inches pipe			
140-08-08-RIWT0001	$(1/2" + 1" 1/4) = (12,70 + 31,75 \text{ mm})$	9,65 Kg.	1.016,00 €
140-08-08-RIWT0002	$(1" + 3/4") = (25,40 + 19,05 \text{ mm})$	9,80 Kg.	1.016,00 €
140-08-08-RIWT0003	$1" 1/2 = 38,1 \text{ mm}$	9,40 Kg.	1.016,00 €
140-08-08-RIWT0004	$2" = 50,8 \text{ mm}$	8,45 Kg.	1.016,00 €
140-08-08-RIWT0005	$2" 1/2 = 63,5 \text{ mm}$	7,25 Kg.	1.016,00 €
140-08-08-RIWT0006	$3" = 76,2 \text{ mm}$	12,30 Kg.	1.177,00 €
140-08-08-RIWT0007	$3" 1/2 = 88,9 \text{ mm}$	10,50 Kg.	1.177,00 €
140-08-08-RIWT0008	$4" = 101,6 \text{ mm}$	8,50 Kg.	1.177,00 €

Digital radius gauge

High precision digital radius gauge

Especially designed for measuring radii on profiles.

The High precision digital radius gauge allows the user to have a direct and immediate reading of inner and outer radius in a range from 55 to 11.250 millimeters or from 2" to 443" inches.

The High precision digital radius gauge measures radii in spherical objects such as tubes, profiles and pipes in a quick and accurate way.

It is really fast and easy to use! It indicates the inner or outer radius of the part we are bending without removing it from the machine and without needing to previously draw and cut a guide template.

Reference	140-MED08-00001
Measurement scope	De 55 a 11.250 mm o de 2" a 443"
Error tolerance over the radius	$\Delta R = (0.01 * R) \text{mm}$
Error toler. over the touch sensor	$\Delta L = 0.02 \text{mm}$
Power supply	Pila de litio 3V CR2032
Radius gauge dimensions	250x60x40 mm
100 arc meter measuring range	R 65 to 625mm / R 2" to 24"
200 arc meter measuring range	R 450 to 2.500mm / R 18" to 98"
300 arc meter measuring range	R 650 to 11.250mm / R 25" to 443"
Weight	1,3 Kg
PRICE	1.897,00 €



- Includes 3V CR2032 lithium battery
- Includes 3 measurement arcs (100, 200 and 300 mm).
- Supplied with a shock-resistant stainless Steel briefcase.

Accessories for Digital radius gauge

400mm High precision arc meter for 20000mm radius



Reference: 140-MED08-00002

Additional arc to measure up to 20,000mm / 787"

Measuring range: From R 1,150 to 20,000mm / From R 45" to 787"

Weight: 0,300Kg.

PRICE: **700,00 €**

Non-Mandrel Pipe Benders

Non-mandrel pipe bender CC60

The new generation of CC60 non-mandrel pipe benders makes up to 180° curves on hollow pipes with the best finish, the greatest speed and thinner than other machines in the same category. Pipes may be round, oval, square, rectangular... made of different materials, iron, aluminum, stainless steel, copper...

Maximum working stroke: 60.3 mm or 2" Schedule-40 or 2" 1/4 x 4 mm.

Reference	100-17-01-001
Engine power	1,1 KW / 1,5 HP
Tension	230 V Single-phase 50/60 Hz
Automatic rotation speed	From 1,1 to 3,5 r.p.m.
Intensity	5 A
Minimum radius of curvature	3 times the pipe diameter
Maximum radius of curvature	320 mm
Maximum working stroke on round steel pipe	60,3mm or 2" Schedule-40 or 2" 1/4 x 4mm.
Maximum angle of curvature	180°
Dimensions	630x1000x1150 mm
Weight	365 Kg
PRICE	11.552,00 €



Nargesa tube and pipes benders are controlled with a very intuitive and easy-to-use 7" color touchscreen with the latest 4.0 technology. **Just enter the pipe dimensions, thickness, angle of the curve or curves and choose a die from the library and the control programs the rest of the parameters automatically;** elastic recovery correction (springback), recommended rotation speed, whether a tool post support is necessary or not, and if the intended curve is possible... All of this may be modified by the end user based on their own needs. These are some of the most relevant features of this control system.

Accessories for Non-Mandrel Pipe Bender CC60

Accessories for round pipes in millimeters · 12 to 60 mm



Rollers made of treated Steel. Units suitable for bending all types of round pipes 12 to 60 millimeters.

The following is supplied with the unit: A main roller, a counter-shape, a clamp with a fastener

Check with the manufacturer for other dimensions

Ø Ext.	Radius	Min. thickness	Max. thickness	Weight	PRICE
Set diameter 12mm Radius 60					REF: 140-17-01-10012
12 mm	60 mm	1 mm	5 mm	3,26 Kg	616,00 €
Set diameter 15mm Radius 60					REF: 140-17-01-10001
15 mm	4D=60 mm	1 mm	5 mm	3,18 Kg	616,00 €
Set diameter 18mm Radius 60					REF: 140-17-01-10010
18 mm	60 mm	1 mm	5 mm	3,11 Kg	616,00 €
Set diameter 20mm Radius 60					REF: 140-17-01-10002
20 mm	3D=60 mm	1 mm	5 mm	3,22 Kg	616,00 €
Set diameter 22mm Radius 66					REF: 140-17-01-10014
22 mm	3D=66 mm	1 mm	5 mm	4,10 Kg	616,00 €
Set diameter 25mm Radius 75					REF: 140-17-01-10003
25 mm	3D=75 mm	1,2 mm	5 mm	5,55 Kg	616,00 €
Set diameter 28mm Radius 84					REF: 140-17-01-10011
28 mm	3D=84 mm	1,2 mm	5 mm	7,28 Kg	685,00 €
Set diameter 30mm Radius 90					REF: 140-17-01-10004
30 mm	3D=90 mm	1,2 mm	5 mm	8,29 Kg	685,00 €
Set diameter 32mm Radius 98					REF: 140-17-01-10013
32 mm	3D=98 mm	1,5 mm	5 mm	10,16 Kg	791,00 €
Set diameter 35mm Radius 105					REF: 140-17-01-10005
35 mm	3D=105 mm	1,5 mm	5 mm	12,14 Kg	791,00 €
Set diameter 40mm Radius 120					REF: 140-17-01-10006
40 mm	3D=120 mm	1,5 mm	5 mm	17,11 Kg	1.043,00 €
Set diameter 50mm Radius 150					REF: 140-17-01-10007
50 mm	3D=150 mm	2 mm	5 mm	31,41 Kg	1.284,00 €
Set diameter 60mm Radius 180					REF: 140-17-01-10008
60 mm	3D=180 mm	2 mm	2,5 mm	40,88 Kg	1.941,00 €

Accessories for Non-Mandrel Pipe Bender CC60

Accessories for 60mm round pipes



Rollers made of treated steel. Suitable kit to bend 60mm tube of 3mm wall thickness or thicker.

The following is supplied with the unit: A main roller, a clamp with a fastener, a support holder

Check with the manufacturer for other dimensions

Supporting Roller Kit REF: 140-17-01-00002 is required

Ø Ext.	Radius	Min. thickness	Max. thickness	Weight	PRICE
Set diameter 60mm Radius 180 with support holder					REF: 140-17-01-10009
60 mm	3D=180 mm	3mm	4 mm	40,58 Kg	1.577,00 €

* The walls with more thickness to the established one and the materials with more resistance, reduce the capacities of the machine.

Accessories for Non-Mandrel Pipe Bender CC60

Accessories for round pipes 3/8" to 1" 1/2 Schedule



Rollers made of treated Steel. Units suitable for bending all types of round pipes 3/8" to 1" 1/2 Schedule.

The following is supplied with the unit: A main roller, a counter-shape, a clamp with a fastener

Check with the manufacturer for other dimensions

Ø Ext.	Ø Ext.	Radius	SCH10	SCH40	SCH80	SCH160	Weight	PRICE
Set diameter 17,10mm Radius 60mm Diameter 3/8" Schedule							REF: 140-17-01-20001	
3/8"	17,1 mm	60 mm	1,65 mm	2,31 mm	3,20 mm	--	4,22 Kg	616,00 €
Set diameter 21,30mm Radius 63,9mm Diameter 1/2" Schedule							REF: 140-17-01-20002	
1/2"	21,3 mm	3D=63,9 mm	2,11 mm	2,77 mm	3,73 mm	4,78 mm	3,56 Kg	616,00 €
Set diameter 26,90mm Radius 80,1mm Diameter 3/4" Schedule							REF: 140-17-01-20003	
3/4"	26,9 mm	3D=80,1 mm	2,11 mm	2,87 mm	3,91 mm	5,56 mm	6,74 Kg	685,00 €
Set diameter 33,70mm Radius 101,1mm Diameter 1" Schedule							REF: 140-17-01-20004	
1"	33,7 mm	3D=101,1 mm	2,77 mm	3,38 mm	4,55 mm	6,35 mm	11,18 Kg	791,00 €
Set diameter 42,40mm Radius 127,2mm Diameter 1" 1/4 Schedule							REF: 140-17-01-20005	
1" 1/4	42,4 mm	3D=127,2 mm	2,77 mm	3,56 mm	4,85 mm	6,35 mm	18,86 Kg	1.128,00 €
Set diameter 48,30mm Radius 144,9mm Diameter 1" 1/2 Schedule							REF: 140-17-01-20006	
1" 1/2	48,3 mm	3D=144,9 mm	2,77 mm	3,68 mm	5,08 mm	--	27,05 Kg	1.284,00 €

Accessories for 2" Schedule round pipes



Rollers made of treated steel. Suitable kit to bend 2" tube of 2,77mm wall thickness or thicker.

The following is supplied with the unit: A main roller, a clamp with a fastener, a support holder

Check with the manufacturer for other dimensions

Supporting Roller Kit REF: 140-17-01-00002 is required

Ø Ext.	Ø Ext.	Radius	SCH10	SCH40	SCH80	SCH160	Weight	PRICE
Set diameter 60,3mm Radius 180,9mm Diameter 2" Schedule							REF: 140-17-01-20007	
2"	60,3 mm	3D=180,9 mm	2,77 mm	3,91 mm	--	--	45,75 Kg	1.577,00 €

* All capacities are based on the norm of carbon steel tubes according to ASTM, Standard A-53 grade A with a maximum resistance strength of 330MPa. The walls with more thickness to the established one and the materials with more resistance, reduce the capacities of the machine. Check with your material supplier for the specifications of this one.

Accessories for Non-Mandrel Pipe Bender CC60

Accessories for round pipes in inches · 1/2" to 2" 1/4 inches



Rollers made of treated Steel. Units suitable for bending all types of round pipes 1/2" to 2" 1/4 inches.

The following is supplied with the unit: A main roller, a counter-shape, a clamp with a fastener

Check with the manufacturer for other dimensions

Ø Ext.	Ø Ext.	Radius	Min. thickness	Max. thickness	Weight	PRICE
Set diameter 9,52mm Radius 60mm Diameter 3/8" inches					REF: 140-17-01-30012	
3/8"	9,52 mm	60 mm	1 mm	4 mm	3,40 Kg	616,00 €
Set diameter 12,7mm Radius 60mm Diameter 1/2" inches					REF: 140-17-01-30011	
1/2"	12,7 mm	60 mm	1 mm	4 mm	3,37 Kg	616,00 €
Set diameter 15,88mm Radius 60mm Diameter 5/8" inches					REF: 140-17-01-30001	
5/8"	15,88 mm	60 mm	1 mm	4 mm	3,61 Kg	616,00 €
Set diameter 19,05mm Radius 60mm Diameter 3/4" inches					REF: 140-17-01-30002	
3/4"	19,05 mm	60 mm	1 mm	4 mm	2,79 Kg	616,00 €
Set diameter 22,22mm Radius 66mm Diameter 7/8" inches					REF: 140-17-01-10014	
7/8"	22,22 mm	66 mm	1 mm	5 mm	4,10 Kg	616,00 €
Set diameter 25,40mm Radius 76,20mm Diameter 1" inches					REF: 140-17-01-30003	
1"	25,40 mm	3D=76,2 mm	1,2 mm	5 mm	5,72 Kg	616,00 €
Set diameter 28,57mm Radius 85,7mm Diameter 1" 1/8 inches					REF: 140-17-01-30009	
1" 1/8	28,57 mm	3D=85,7 mm	1,5 mm	5 mm	7,70 Kg	791,00 €
Set diameter 31,75mm Radius 95,25mm Diameter 1" 1/4 inches					REF: 140-17-01-30004	
1" 1/4	31,75 mm	3D=95,25 mm	1,5 mm	6 mm	10,21 Kg	791,00 €
Set diameter 38,10mm Radius 114,30mm Diameter 1" 1/2 inches					REF: 140-17-01-30005	
1" 1/2	38,10 mm	3D=114,3 mm	1,5 mm	7 mm	15,69 Kg	1.043,00 €
Set diameter 44,45mm Radius 133,35mm Diameter 1" 3/4 inches					REF: 140-17-01-30010	
1" 3/4	44,45 mm	3D=133,35 mm	2 mm	5 mm	21,86 Kg	1.284,00 €
Set diameter 50,8mm Radius 152,4mm Diameter 2" inches					REF: 140-17-01-30006	
2"	50,80 mm	3D=152,4 mm	2 mm	5 mm	32,24 Kg	1.284,00 €
Set diameter 57,15mm Radius 171,45mm Diameter 2" 1/4 inches					REF: 140-17-01-30007	
2" 1/4	57,15 mm	3D=171,45 mm	2 mm	2,5 mm	36,13 Kg	1.941,00 €

Accessories for Non-Mandrel Pipe Bender CC60

Accessories for 2" 1/4 round pipes



Rollers made of treated Steel. Suitable kit to bend 2" 1/4 tube of 3mm wall thickness or thicker.

The following is supplied with the unit: A main roller, a clamp with a fastener, a support holder

Check with the manufacturer for other dimensions

Supporting Roller Kit REF: 140-17-01-00002 is required

Ø Ext.	Ø Ext.	Radius	Min. thickness	Max. thickness	Weight	PRICE
Set diameter 57,15mm Radius 171,45mm Diameter 2" 1/4 with support holder					REF: 140-17-01-30008	
2" 1/4	57,15 mm	3D=171,45 mm	3 mm	4 mm	35,91 Kg	1.577,00 €

* The walls with more thickness to the established one and the materials with more resistance, reduce the capacities of the machine.

Supporting Roller Kit CC60

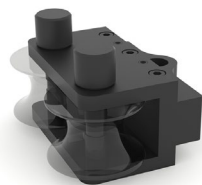

Reference: 140-17-01-00002

The CC60 Supporting Roller Kit is used to bend:

- 60mm tube of 3mm wall thickness or thicker
- 2" Schedule tube of 2,77mm wall thickness or thicker
- 2" 1/4 tube of 3mm wall thickness or thicker

Weight: 9,85Kg

PRECIO: 658,00 €

Accessories for Non-Mandrel Pipe Bender CC60

Accessories for square pipes in millimeters · 20 to 40 mm



Rollers made of treated Steel. Units suitable for bending all types of square pipes 20 to 40mm.

The following is supplied with the unit: A main roller, a counter-shape, a clamp with a fastener

Check with the manufacturer for other dimensions

Section	Radius	Min. thickness	Max. thickness	Weight	PRICE
Square Tube Die Set 20mm Radius 100mm				REF: 140-17-01-10101	
20x20 mm	5D=100 mm	1,5 mm	4 mm	11,1 Kg	989,00 €
Square Tube Die Set 25mm Radius 115mm				REF: 140-17-01-10102	
25x25 mm	115 mm	2 mm	4 mm	14,75 Kg	1.315,00 €
Square Tube Die Set 30mm Radius 135mm				REF: 140-17-01-10103	
30x30 mm	135 mm	2 mm	4 mm	22 Kg	1.470,00 €
Square Tube Die Set 40mm Radius 165mm				REF: 140-17-01-10104	
40x40 mm	165 mm	2 mm	5 mm	34,15 Kg	1.817,00 €

Accessories for square pipes in inches · 3/4" to 1" 1/2 inches



Rollers made of treated Steel. Units suitable for bending all types of square pipes 3/4" to 1" 1/2 inches.

The following is supplied with the unit: A main roller, a counter-shape, a clamp with a fastener

Check with the manufacturer for other dimensions

Section	Section	Radius	Radius	Min. Thick.	Max. Thick.	Weight	PRICE
Square Tube Die Set 3/4" (19,05mm) Radius 4" (101,6mm)				REF: 140-17-01-30101			
3/4"x3/4"	19,05x19,05mm	4"	101,6mm	1,5 mm	4 mm	11,5 Kg	989,00 €
Square Tube Die Set 1" (25,4mm) Radius 4,5" (114,3mm)				REF: 140-17-01-30102			
1"x1"	25,4x25,4mm	4" 1/2	114,3mm	2 mm	4 mm	14,6 Kg	1.315,00 €
Square Tube Die Set 1" 1/4 (31,75mm) Radius 5,5" (139,7mm)				REF: 140-17-01-30103			
1" 1/4x1" 1/4	31,75x31,75mm	5" 1/2	139,7mm	2 mm	4 mm	23,3 Kg	1.470,00 €
Square Tube Die Set 1" 1/2 (38,1mm) Radius 6,5" (165,1mm)				REF: 140-17-01-30104			
1" 1/2x1" 1/2	38,1x38,1mm	6" 1/2	165,1mm	2 mm	5 mm	34,6 Kg	1.662,00 €

Accessories for Non-Mandrel Pipe Bender CC60

Nargesa BEND8 aerosol lubricant



This is a high-additive and low-viscosity aerosol oil. Contains PTFE. Does not contain silicone.

- Enables the finish on the outer bend
- Inhibits roughness and inner marks
- Reduces wear of the tooling
- Especially designed for tubes of small thickness
- Lubricates to reduce friction
- Avoids and dissolves corrosion
- Gives shine and protects
- Cleans up and removes dirt

Reference	Description	Quantity	Weight	PRICE
060-SPR-00003	Aerosol lubricant bottle	400ml	0,39Kg	22,00 €
060-SPR-00004	Box of 12 bottles	12x400ml	4,83Kg	179,00 €

CC60 2-axis positioning gauge

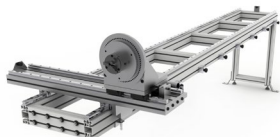

The gauge of the CC60 allows to make mass produced parts, much faster, more accurate and repetitively.

- Adjustable longitudinal positioning with 6 positions
- Angular head rotation every 5 degrees
- Four-clamp plate adjustable to round and square tube
- Longitudinal movement with high precision linear guides
- Automatic anti-collision control
- Easy handling and preparation for difficult parts

Reference	Gauge length	Maximum capacity	Weight	PRICE
140-17-01-50000	3000mm	60,3mm, 2" Schedule	125Kg	6.382,00 €

Non-Mandrel Pipe Benders

Non-mandrel pipe bender CC90

The new generation of CC90 non-mandrel pipe benders makes up to 180° curves on hollow pipes with the best finish, the greatest speed and thinner than other machines in the same category. Pipes may be round, oval, square, rectangular...made of different materials, iron, aluminum, stainless steel, copper...

Maximum working stroke: 88.9 mm or 3" Schedule 40 or 3" 1/2 Whitworth or 3" ISO x 6 mm.

Reference	100-17-02-001
Engine power	2,2 Kw / 3 HP
Tension	230/400 V 50/60 Hz
Automatic rotation speed	From 0,75 to 2,2 r.p.m.
Intensity	9/5 A
Minimum radius of curvature	3 times the pipe diameter
Maximum radius of curvature	390 mm
Maximum working stroke on round steel pipe	90mm or 3" Schedule-40 or 3" 1/2 x 6mm.
Maximum angle of curvature	180°
Dimensions	700x1300x1360 mm
Weight	860 Kg
PRICE	21.564,00 €



Nargesa tube and pipes benders are controlled with a very intuitive and easy-to-use 7" color touchscreen with the latest 4.0 technology. **Just enter the pipe dimensions, thickness, angle of the curve or curves and choose a die from the library and the control programs the rest of the parameters automatically;** elastic recovery correction (springback), recommended rotation speed, whether a tool post support is necessary or not, and if the intended curve is possible... All of this may be modified by the end user based on their own needs. These are some of the most relevant features of this control system.

Accessories for Non-Mandrel Pipe Bender CC90

Accessories for round pipes in millimeters · 12 to 80 mm



Rollers made of treated Steel. Units suitable for bending all types of round pipes 12 to 80 millimeters.

The following is supplied with the unit: A main roller, a counter-shape, a clamp with a fastener

Check with the manufacturer for other dimensions

Ø Ext.	Radius	Min. thickness	Max. thickness	Weight	PRICE
Set diameter 12mm Radius 60					REF: 140-17-01-10012
12 mm	60 mm	1 mm	5 mm	3,26 Kg	616,00 €
Set diameter 15mm Radius 60					REF: 140-17-01-10001
15 mm	4D=60 mm	1 mm	5 mm	3,18 Kg	616,00 €
Set diameter 18mm Radius 60					REF: 140-17-01-10010
18 mm	60 mm	1 mm	5 mm	3,11 Kg	616,00 €
Set diameter 20mm Radius 60					REF: 140-17-01-10002
20 mm	3D=60 mm	1 mm	5 mm	3,22 Kg	616,00 €
Set diameter 22mm Radius 66					REF: 140-17-01-10014
22 mm	3D=66 mm	1 mm	5 mm	4,10 Kg	616,00 €
Set diameter 25mm Radius 75					REF: 140-17-01-10003
25 mm	3D=75 mm	1,2 mm	5 mm	5,55 Kg	616,00 €
Set diameter 28mm Radius 84					REF: 140-17-01-10011
28 mm	3D=84 mm	1,2 mm	5 mm	7,28 Kg	685,00 €
Set diameter 30mm Radius 90					REF: 140-17-01-10004
30 mm	3D=90 mm	1,2 mm	5 mm	8,29 Kg	685,00 €
Set diameter 32mm Radius 98					REF: 140-17-01-10013
32 mm	3D=98 mm	1,5 mm	5 mm	10,16 Kg	791,00 €
Set diameter 35mm Radius 105					REF: 140-17-01-10005
35 mm	3D=105 mm	1,5 mm	5 mm	12,14 Kg	791,00 €
Set diameter 40mm Radius 120					REF: 140-17-01-10006
40 mm	3D=120 mm	1,5 mm	5 mm	17,11 Kg	1.043,00 €
Set diameter 50mm Radius 150					REF: 140-17-01-10007
50 mm	3D=150 mm	2 mm	5 mm	31,41 Kg	1.284,00 €
Set diameter 60mm Radius 180					REF: 140-17-01-10008
60 mm	3D=180 mm	2 mm	5 mm	40,88 Kg	1.941,00 €
Set diameter 70mm Radius 210					REF: 140-17-02-10001
70 mm	3D=210 mm	3,6 mm	6 mm	72,40 Kg	2.565,00 €
Set diameter 80mm Radius 240					REF: 140-17-02-10002
80 mm	3D=240 mm	4 mm	5 mm	88,17 Kg	2.965,00 €

Accessories for Non-Mandrel Pipe Bender CC90

Accessories for 90mm round pipes



Rollers made of treated steel. Suitable kit to bend 90mm tube of 4mm wall thickness or thicker.

The following is supplied with the unit: A main roller, a clamp with a fastener, a support holder

Check with the manufacturer for other dimensions

Supporting Roller Kit REF: 140-17-02-00002 is required

Ø Ext.	Radius	Min. thickness	Max. thickness	Weight	PRICE
Set diameter 90mm Radio 270					REF: 140-17-02-10003
90 mm	3D=270 mm	4 mm	5 mm	114,36 Kg	3.419,00 €

* The walls with more thickness to the established one and the materials with more resistance, reduce the capacities of the machine.

Accessories for Non-Mandrel Pipe Bender CC90

Accessories for round pipes 3/8" to 2" 1/2 Schedule



Rollers made of treated Steel. Units suitable for bending all types of round pipes 3/8" to 2" 1/2 Schedule.

The following is supplied with the unit: A main roller, a counter-shape, a clamp with a fastener

Check with the manufacturer for other dimensions

Ø Ext.	Ø Ext.	Radius	SCH10	SCH40	SCH80	SCH160	Weight	PRICE
Set diameter 17,10mm Radius 60mm Diameter 3/8" Schedule							REF: 140-17-01-20001	
3/8"	17,1 mm	60 mm	1,65 mm	2,31 mm	3,20 mm	--	4,22 Kg	616,00 €
Set diameter 21,30mm Radius 63,9mm Diameter 1/2" Schedule							REF: 140-17-01-20002	
1/2"	21,3 mm	3D=63,9 mm	2,11 mm	2,77 mm	3,73 mm	4,78 mm	3,56 Kg	616,00 €
Set diameter 26,90mm Radius 80,1mm Diameter 3/4" Schedule							REF: 140-17-01-20003	
3/4"	26,9 mm	3D=80,1 mm	2,11 mm	2,87 mm	3,91 mm	5,56 mm	6,74 Kg	685,00 €
Set diameter 33,70mm Radius 101,1mm Diameter 1" Schedule							REF: 140-17-01-20004	
1"	33,7 mm	3D=101,1 mm	2,77 mm	3,38 mm	4,55 mm	6,35 mm	11,18 Kg	791,00 €
Set diameter 42,40mm Radius 127,2mm Diameter 1" 1/4 Schedule							REF: 140-17-01-20005	
1" 1/4	42,4 mm	3D=127,2 mm	2,77 mm	3,56 mm	4,85 mm	6,35 mm	18,86 Kg	1.128,00 €
Set diameter 48,30mm Radius 144,9mm Diameter 1" 1/2 Schedule							REF: 140-17-01-20006	
1" 1/2	48,3 mm	3D=144,9 mm	2,77 mm	3,68 mm	5,08 mm	--	27,05 Kg	1.284,00 €
Set diameter 60,30mm Radius 180,9mm Diameter 2" Schedule							REF: 140-17-02-20001	
2"	60,30 mm	3D=180,9 mm	2,77 mm	3,91 mm	5,54 mm	--	45,75 Kg	1.941,00 €
Set diameter 73mm Radius 219mm Diameter 2" 1/2 Schedule							REF: 140-17-02-20002	
2" 1/2	73,0 mm	3D=219 mm	3,05 mm	5,16 mm	7,01 mm	--	72,00 Kg	2.965,00 €

Accessories for 3" Schedule round pipes



Rollers made of treated steel. Suitable kit to bend 3" Schedule tube of 3,05mm wall thickness or thicker.

The following is supplied with the unit: A main roller, a clamp with a fastener, a support holder

Check with the manufacturer for other dimensions

Supporting Roller Kit REF: 140-17-02-00002 is required

Ø Ext.	Ø Ext.	Radius	SCH10	SCH40	SCH80	SCH160	Weight	PRICE
Set diameter 88,9mm Radius 266,7mm Diameter 3" Schedule							REF: 140-17-02-30003	
3"	88,9 mm	3D=266,7 mm	3,05 mm	5,49 mm	--	--	110,80 Kg	3.419,00 €

* All capacities are based on the norm of carbon steel tubes according to ASTM, Standard A-53 grade A with a maximum resistance strength of 330MPa. The walls with more thickness to the established one and the materials with more resistance, reduce the capacities of the machine. Check with your material supplier for the specifications of this one.

Accessories for Non-Mandrel Pipe Bender CC90

Accessories for round pipes in inches · 1/2" to 3" inches



Rollers made of treated Steel. Units suitable for bending all types of round pipes 1/2" to 3" inches.

The following is supplied with the unit: A main roller, a counter-shape, a clamp with a fastener

Check with the manufacturer for other dimensions

Ø Ext.	Ø Ext.	Radius	Min. thickness	Max. thickness	Weight	PRICE
Set diameter 9,52mm Radius 60mm Diameter 3/8" inches					REF: 140-17-01-30012	
3/8"	9,52 mm	60 mm	1 mm	4 mm	3,40 Kg	616,00 €
Set diameter 12,7mm Radius 60mm Diameter 1/2" inches					REF: 140-17-01-30011	
1/2"	12,7 mm	60 mm	1 mm	4 mm	3,37 Kg	616,00 €
Set diameter 15,88mm Radius 60mm Diameter 5/8" inches					REF: 140-17-01-30001	
5/8"	15,88 mm	60 mm	1 mm	4 mm	3,61 Kg	616,00 €
Set diameter 19,05mm Radius 60mm Diameter 3/4" inches					REF: 140-17-01-30002	
3/4"	19,05 mm	60 mm	1 mm	4 mm	2,79 Kg	616,00 €
Set diameter 22,22mm Radius 66mm Diameter 7/8" inches					REF: 140-17-01-10014	
7/8"	22,22 mm	66 mm	1 mm	5 mm	4,10 Kg	616,00 €
Set diameter 25,40mm Radius 76,20mm Diameter 1" inches					REF: 140-17-01-30003	
1"	25,40 mm	3D=76,2 mm	1,2 mm	5 mm	5,72 Kg	616,00 €
Set diameter 28,57mm Radius 85,7mm Diameter 1" 1/8 inches					REF: 140-17-01-30009	
1" 1/8	28,57 mm	3D=85,7 mm	1,5 mm	5 mm	7,70 Kg	791,00 €
Set diameter 31,75mm Radius 95,25mm Diameter 1" 1/4 inches					REF: 140-17-01-30004	
1" 1/4	31,75 mm	3D=95,25 mm	1,5 mm	6 mm	10,21 Kg	791,00 €
Set diameter 38,10mm Radius 114,30mm Diameter 1" 1/2 inches					REF: 140-17-01-30005	
1" 1/2	38,10 mm	3D=114,3 mm	1,5 mm	7 mm	15,69 Kg	1.043,00 €
Set diameter 44,45mm Radius 133,35mm Diameter 1" 3/4 inches					REF: 140-17-01-30010	
1" 3/4	44,45 mm	3D=133,35 mm	2 mm	5 mm	21,86 Kg	1.284,00 €
Set diameter 50,8mm Radius 152,4mm Diameter 2" inches					REF: 140-17-01-30006	
2"	50,80 mm	3D=152,4 mm	2 mm	5 mm	32,24 Kg	1.284,00 €
Set diameter 57,15mm Radius 171,45mm Diameter 2" 1/4 inches					REF: 140-17-01-30007	
2" 1/4	57,15 mm	3D=171,45 mm	2 mm	5 mm	36,13 Kg	1.941,00 €
Set diameter 63,5mm Radius 190,5mm Diameter 2" 1/2 inches					REF: 140-17-02-30001	
2" 1/2	63,50 mm	3D=190,5 mm	3 mm	8,64 mm	40,50 Kg	2.565,00 €
Set diameter 76,2mm Radius 228,6mm Diameter 3" inches					REF: 140-17-02-30002	
3"	76,20 mm	3D=228,6 mm	3 mm	7,21 mm	80,68 Kg	2.565,00 €

Accessories for Non-Mandrel Pipe Bender CC90

Accessories for 3" 1/2 round pipes



Rollers made of treated Steel. Suitable kit to bend 3" 1/2 tube of 4mm wall thickness or thicker.

The following is supplied with the unit: A main roller, a clamp with a fastener, a support holder

Check with the manufacturer for other dimensions

Supporting Roller Kit REF: 140-17-02-00002 is required

Ø Ext.	Ø Ext.	Radius	Min. thickness	Max. thickness	Weight	PRICE
Set diameter 88,9mm Radius 266,7mm Diameter 3" 1/2 inches					REF: 140-17-02-30003	
3" 1/2	88,9 mm	3D=266,7 mm	4 mm	6,05 mm	110,80 Kg	3.419,00 €

* The walls with more thickness to the established one and the materials with more resistance, reduce the capacities of the machine.

Supporting Roller Kit CC90

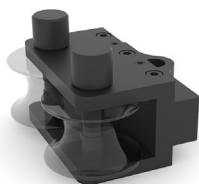

Reference: 140-17-02-00002

The CC90 Supporting Roller Kit is used to bend:

- 90mm tube of 4mm wall thickness or thicker
- 3" Schedule tube of 3,05mm wall thickness or thicker
- 3" 1/2 tube of 4mm wall thickness or thicker.

Weight: 24,57 Kg.

PRICE: 803,00 €

Accessories for Non-Mandrel Pipe Bender CC90

Accessories for square pipes in millimeters · 20 to 50 mm



Rollers made of treated Steel. Units suitable for bending all types of square pipes 20 to 50mm.

The following is supplied with the unit: A main roller, a counter-shape, a clamp with a fastener

Check with the manufacturer for other dimensions

Section	Radius	Min. thickness	Max. thickness	Weight	PRICE
Square Tube Die Set 20mm Radius 100mm				REF: 140-17-01-10101	
20x20 mm	5D=100 mm	1,5 mm	4 mm	11,1 Kg	989,00 €
Square Tube Die Set 25mm Radius 115mm				REF: 140-17-01-10102	
25x25 mm	115 mm	2 mm	4 mm	14,75 Kg	1.315,00 €
Square Tube Die Set 30mm Radius 135mm				REF: 140-17-01-10103	
30x30 mm	135 mm	2 mm	4 mm	22 Kg	1.470,00 €
Square Tube Die Set 40mm Radius 165mm				REF: 140-17-01-10104	
40x40 mm	165 mm	2 mm	5 mm	34,15 Kg	1.817,00 €
Square Tube Die Set 50mm Radius 180mm				REF: 140-17-02-10101	
50x50 mm	180 mm	2,5 mm	5 mm	45,7 Kg	1.897,00 €

Accessories for square pipes in inches · 3/4" to 2" inches



Rollers made of treated Steel. Units suitable for bending all types of square pipes 3/4" to 2" inches.

The following is supplied with the unit: A main roller, a counter-shape, a clamp with a fastener

Check with the manufacturer for other dimensions

Section	Section	Radius	Radius	Min. Thick.	Max. Thick.	Weight	PRICE
Square Tube Die Set 3/4" (19,05mm) Radius 4" (101,6mm)				REF: 140-17-01-30101			
3/4"x3/4"	19,05x19,05mm	4"	101,6mm	1,5 mm	4 mm	11,5 Kg	989,00 €
Square Tube Die Set 1" (25,4mm) Radius 4,5" (114,3mm)				REF: 140-17-01-30102			
1"x1"	25,4x25,4mm	4" 1/2	114,3mm	2 mm	4 mm	14,6 Kg	1.315,00 €
Square Tube Die Set 1" 1/4 (31,75mm) Radius 5,5" (139,7mm)				REF: 140-17-01-30103			
1" 1/4x1" 1/4	31,75x31,75mm	5" 1/2	139,7mm	2 mm	4 mm	23,3 Kg	1.470,00 €
Square Tube Die Set 1" 1/2 (38,1mm) Radius 6,5" (165,1mm)				REF: 140-17-01-30104			
1" 1/2x1" 1/2	38,1x38,1mm	6" 1/2	165,1mm	2 mm	5 mm	34,6 Kg	1.662,00 €
Square Tube Die Set 1" 3/4 (44,45mm) Radius 6,75" (171,45mm)				REF: 140-17-02-30101			
1" 3/4x1" 3/4	44,45x44,45mm	6" 3/4	171,45mm	2,5 mm	5 mm	39 Kg	1.817,00 €
Square Tube Die Set 2" (50,8mm) Radius 7" (177,8mm)				REF: 140-17-02-30102			
2"x2"	50,8x50,8mm	7"	177,8mm	2,5 mm	5 mm	44 Kg	1.897,00 €

Accessories for Non-Mandrel Pipe Bender CC90

Nargesa BEND8 aerosol lubricant



This is a high-additive and low-viscosity aerosol oil. Contains PTFE. Does not contain silicone.

- Enables the finish on the outer bend
- Inhibits roughness and inner marks
- Reduces wear of the tooling
- Especially designed for tubes of small thickness
- Lubricates to reduce friction
- Avoids and dissolves corrosion
- Gives shine and protects
- Cleans up and removes dirt

Reference	Description	Quantity	Weight	PRICE
060-SPR-00003	Aerosol lubricant bottle	400ml	0,39Kg	22,00 €
060-SPR-00004	Box of 12 bottles	12x400ml	4,83Kg	179,00 €

CC90 2-axis positioning gauge

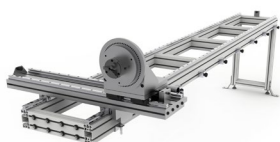

The gauge of the CC90 allows to make mass produced parts, much faster, more accurate and repetitively.

- Adjustable longitudinal positioning with 6 positions
- Angular head rotation every 5 degrees
- Four-clamp plate adjustable to round and square tube
- Longitudinal movement with high precision linear guides
- Automatic anti-collision control
- Easy handling and preparation for difficult parts

Referencia	Gauge length	Maximum capacity	Weight	PRICE
140-17-02-50000	3000mm	90mm, 3" Schedule	135Kg	6.735,00 €

Forging twisting machines

Forging twisting machine MT150A

The twisting machine MT150A Nargesa was patented by Prada Nargesa many years ago. It makes us lead the manufacturing of this kind of machinery. It is made in a welded and mechanized Steel monoblock. It has been thought to transform cold iron. It is ideal for working all kind of ornamental pieces, handrails, scrolls...

Reference	100-01-02-001
Engine Power	0,37 KW / 0,5 HP
2 phased tension	230 V Single phased
Rotary speed	Adjustable 0 to 9 r.p.m.
Twisting maximum capacity	20 mm or 3/4"
Bending maximum capacity	16 mm or 5/8"
Max. Scrolling and bending in flat bar	35x10 mm or 1 1/4"x3/8"
Máx. continued scrolling length	960 mm
Dimensions	2270x635x1115 mm
Weight	260 Kg
PRECIO	7.869,00 €



Accessories for Forging twisting machine MT150A

Flat bent rings 96,100,110mm MT150A

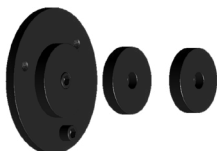

Reference: 140-01-01-00001

Steel Die to make round or square bent, the so called English railing.

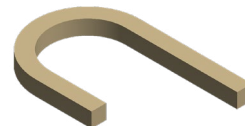

Inner diameter	Max. Capacity	Weight	PRICE
96,100,110mm	Roun or square 16 mm	10 Kg.	505,00 €

Belly top railing die MT150A

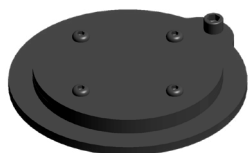

Reference: 140-01-01-00002

Steel Die to make the Belly Top Railing , used in balconies and windows.



Inner diameter	Max. Capacity	Weight	PRICE
225mm	Roun or square 16 mm	12 Kg.	477,00 €

Flat bar bent die MT150A

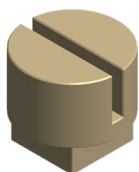

Reference: 140-01-01-00003

Treated Steel die for making flat bar folding operations, handrails or clods in all kinds. Folding with minimum external radius.

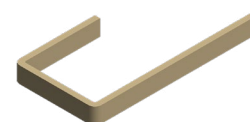

Max. Capacity	Weight	PRICE
40x10 mm flat bar	3,1 Kg.	269,00 €

Edge scrolls MT150A

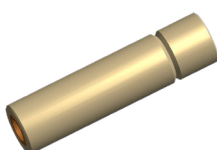

Reference: 140-01-01-00004

Treated steel Die to make scrolls or edge spirals in order to give it a different styling touch, it's commonly used in some specific countries.



Max. capacity	Weight	PRICE
Round or square 16 mm	0,75 Kg.	90,00 €



Accessories for Forging twisting machine MT150A

Baskets tooling MT150A

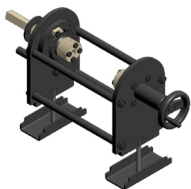

Reference: 140-01-01-00005

Tooling to make all kinds of baskets, in different sizes for square or round bars.

Available tooling for millimeter and inch square sizes



Max. Capacity	Weight	PRICE
4 square or round 10 mm	45 Kg.	2.138,00 €

Forging twisting machines

Forging twisting machine MT500A

The twisting machine MT500A Nargesa was patented by Prada Nargesa many years ago. It makes us lead the manufacturing of this kind of machinery. It is made in a welded and mechanized Steel monoblock. It has been thought to transform cold iron. It is ideal for working all kind of ornamental pieces, handrails, scrolls...

Reference	100-01-03-001
Engine Power	4 KW / 5,5 HP
Three-phased tension	230 / 400 V
Rotary speed	Adjustable 0 to 10 r.p.m.
Twisting maximum capacity	40 mm or 1 3/8"
Bending maximum capacity	25 mm or 1"
Max. Scrolling and bending in flat bar	50x10 mm or 2"x3/8"
Máy. continued scrolling length	1.620 mm
Dimensions	2200x800x1270 mm
Weight	1350 Kg
PRICE	16.271,00 €



Accessories for Forging twisting machine MT500A

Double eyed tooling



Reference: 140-01-03-00001

Tooling to make the folding commonly called "pig's tail" it's very used in balconies, handrails and many ornamental utilities.

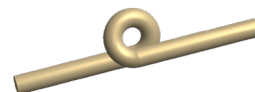

Max. Capacity	Weight	PRICE
16 mm round	35 Kg.	1.989,00 €

Bent pipe die up to 180°

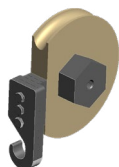

Reference: 140-01-03-00002

Steel die to make curves in pipes with fixed and adjustable radius to different degrees.

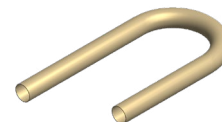

Pipe max. diameter	Pipe min. thickness	Piece radius	Degrees	Weight	PRICE
40mm	3mm	3 x pipe diameter	Max.180 degrees	15/35 Kg.	1.278,00 €

Belly top railing

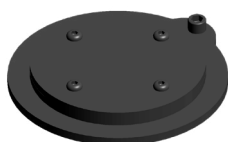

Reference: 140-01-03-00003

Steel die to make Belly top railing commonly used in balconies and windows.



Inner diameter	Max. Capacity	Weight	PRICE
225mm	Round or square 16 mm	12 Kg.	494,00 €

Oval scrolls die

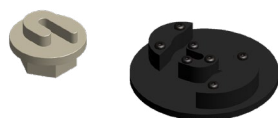

Reference: 140-01-03-00004

Steel die to make oval scrolls for all kind of railings.



Outer diameter	Max. Capacity	Weight	PRICE
240x190mm	Round or square de 16 mm	11 Kg.	1.253,00 €



Accessories for Forging twisting machine MT500A

Flat bent rings 96,100,110mm

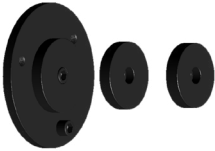

Reference: 140-01-03-00005

Steel die to mke folding operations in round or square bars such as the so called English railings.

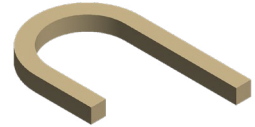

Inner diameter	Max. Capacity	Weight	PRICE
96,100,110mm	Round or square 16 mm	10 Kg.	536,00 €

Edge scrolls die



Reference: 140-01-03-00006

Treated Steel bar to make scrolls or edge spirals in order to give it a different styling touch, it is very used in specific countries.



Max. Capacity	Weight	PRICE
Round or square 25 mm	0,400 Kg.	85,00 €

Baskets tooling



Reference: 140-01-03-00012

Tooling to make all kinds of baskets, different sizes in square or round bars.

Available tooling for millimeter and inch square sizes.



Max. Capacity	Weight	PRICE
4 square or round de 12 mm.	55 Kg.	2.138,00 €

Horizontal Press Brake

Horizontal Press Brake PP200CNC

The versatility of the 20 Tons Horizontal Press Brake Nargesa PP200CNC allows us to bend, fold, cut and shape in cold, stretch and reduce, inlay, notch and assemble...

- **The new ECO mode** of our latest products saves energy and contributes to the conservation of the environment. Nowadays, we know the remarkable importance of saving energy. This is the main reason why our new machinery incorporates an "ECO mode" that automatically disconnects the electrical parts that generate greater energy consumption if a period of inactivity is detected. Thus, when it is necessary to restart the operation, all you have to do is press the pedal to continue working.

We strongly believe that this feature is a core point both for the savings of our clients and for the sustainability of our planet, since we are a company very committed to the environment.

- **Quick start-up:** The machine is shipped fully assembled, it is only required to connect it to the electrical supply and run it.
- **Versatility:** Nargesa PP200 has a catalog with a great deal of optional tooling.
- **Easy fabrication of tooling:** The customer himself or any toolmaker can manufacture dies and punches.

Reference	100-16-01-001
Engine power	2,2 KW / 3 HP to 1400r.p.m
Three-phased tension	230 / 400 V
Working strength	20.000 Kg / 200 KN
Working speed	10 mm/s
Return speed	35 mm/s
Maximum displacement	250 mm
Repetitivity	0,05 mm
Tooling support table	600x1170 mm
Dimensions	660x1180x1130 mm
Weight	665 Kg
PRICE	11.450,00 €



Nargesa horizontal press brakes have a 7" color touch screen control, **very intuitive and easy to handle, with the latest 4.0 technology and a more comfortable and accurate regulation.**

We only have to introduce the material, the thickness, the bending angle, choose the punch and the die from the library and the control will program the rest of the parameters automatically.

Accessories for Horizontal Press Brake

PP200CNC Automated Gauge

The automated gauge is an accessory specifically designed to get the most out of the PP200CNC Horizontal Press Brake, offering the possibility to get, automatically, the positioning of the "X" axis for the different operations programmed and calculated with the ESA S625 CNC control, thus improving the performance of operation and quality of work with this machine.

The automated gauge of the PP200CNC enables the user to make single or mass produced parts with top accuracy, speed and repeatability compared to the previous manual system. These are its main features and functions:

- Drive by ESA servomotor and HTD crowned belts that allow automatic positioning of the "X" axis with a precision of ± 0.02 mm.
- Manual adjustment of the cross slide, "Z" axis to cover all the operation possibilities offered by the PP200CNC horizontal press, folding, punching, bending...
- Longitudinal movements of both carriages using high-precision linear guides and recirculating ball runners.
- Automatic anti-collision control managed by the software itself.
- Easy mechanical and electrical installation for quick set up and run.

Reference	140-16-01-50000
Electrical motor	Servomotor 0,9Nm, 0,520kW, 5000rpm
Electrical tension	480V, 400V ,220V Three-phase 220V Single-phase
X axis stroke length	1210 mm
Z axis stroke length	300 mm
Displacement speed	1000mm /s
Positioning accuracy	± 0.02 mm
Repeatability	± 0.02 mm
Maximum structural load	2.000 Kg
Dimensions	1496x1041x426 mm
Weight	115 Kg
PRICE	7.771,00 €



Accessories for Horizontal Press Brake

Folding die at 161 mm. · V16, 22 35 50 mm PP200CNC

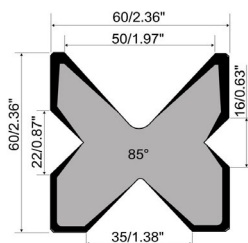

Folding or bending die up to 161mm with 4 openings (16, 22, 35, 50mm). This multi-V die allows 1mm up to 8mm sheet to be folded.

Reference: 125-16-01-00006

V 16: Sheet from 1 to 3mm · M.460.R/16

V 22: Sheet from 2 to 4mm · M.460.R/22

V 35: Sheet from 3 to 6mm · M.460.R/35

V 50: Sheet from 4 to 8mm · M.460.R/50

Max. Folding length: 161mm

Max. Folding thickness: 8mm

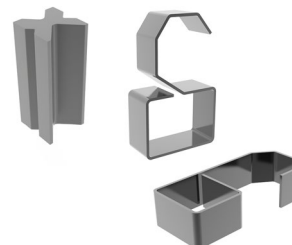

Standard tooling provided along with the machine.

Bending punch at 100 mm and 80°

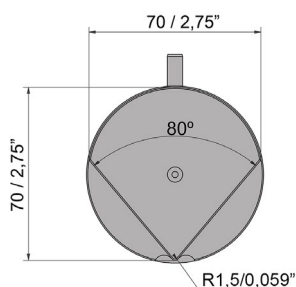

80° bending punch. The punch with an outer diameter of 70 mm allows for creating completely closed shapes with a minimum inner wing of 75 mm.

Reference: 131-16-01-00041 · P.70.80.R1.5

Max. Folding length: 100mm

Standard tooling provided along with the machine.



Baluster forming die 01

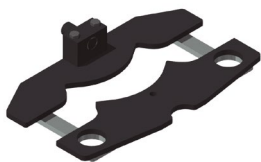

Reference: 140-16-01-00001

Die to form cold forging balusters for grills, gates, fences, handrails...

For other shapes or capacities, request the manufacturer.



Max. width	Thickness	Die length	Weight	PRICE
20mm	4, 5, 6, 8mm	656mm	21Kg	658,00 €

Accessories for Horizontal Press Brake

Ring forming

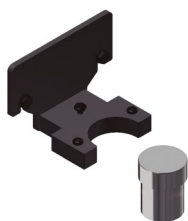

Reference: 140-16-01-00003

Die to form rings or English banister railing, used as ornamental piece in forging railings, gates, fences... for bars bonding.

For other sizes and applications consult the manufacturer

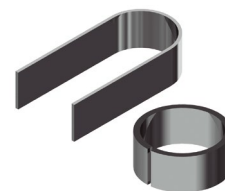

Max. width	Thickness	Outer sizes	Weight	PRICE
50mm	6mm	90mm	9,3Kg	621,00 €

Baluster forming die 4

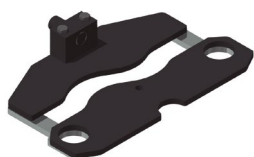

Reference: 140-16-01-00004

Die to form cold forging balusters for grills, gates, fences, handrails...

For other shapes or capacities, request the manufacturer.



Square sizes	Die length	Weight	PRICE
5, 6, 8, 10, 12, 14, 16, 18mm	600mm	20,5 Kg	658,00 €

Bending tool for big radius PP200CNC

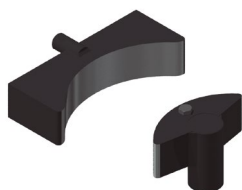

Reference: 140-16-01-00006

Die to form curves in flat bars, pipes, bars or profiles at big radius. It's perfect for bending small series or special parts without requiring a specific custom mold.

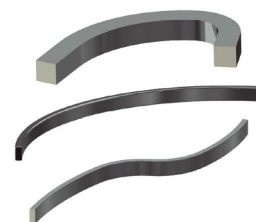

Max. bar capacity	Max. pipe capacity	Min. diameter	Max. diameter	Weight	PRICE
40mm or 1 1/2"	80x80 mm or 3"	300mm	There is no maximum	35 Kg	1.123,00 €

Baluster forming die 08



Reference: 140-16-01-00008

Die to form cold forging balusters for grills, gates, fences, handrails...

For other shapes or capacities, request the manufacturer



Max. width	Thickness	Die length	Weight	PRICE
20mm	4, 5, 6, 8mm	650mm	19,5Kg	658,00 €

Accessories for Horizontal Press Brake

Baluster forming die 09



Reference: 140-16-01-00009

Die to form cold forging balusters for grills, gates, fences, handrails...

For other shapes or capacities, request the manufacturer.



Flat bar size	Die length	Weight	PRICE
5, 6, 8, 10, 12mm	522mm	22Kg	658,00 €

Baluster forming die 10



Reference: 140-16-01-00010

Die to form cold forging balusters shaped parts for grills, so called "belly top railing".

For other shapes or capacities, please consult the manufacturer.



Flat bar size	Die length	Weight	PRICE
12mm	1165mm	50Kg	813,00 €

Baluster forming die 11



Reference: 140-16-01-00011

Die to form cold forging balusters for grills, gates, fences, handrails...

For other shapes or capacities, request the manufacturer.

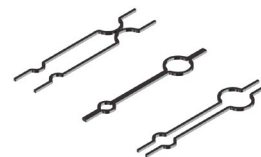

Flat bar size	Die length	Weight	PRICE
6, 8, 10, 12mm	760mm	32,5Kg	658,00 €

Twisted bars forming die

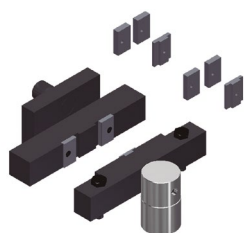

Reference: 140-16-01-00013

Die to bend metal plate, flat bar or square bar to obtain a nice braid twisted effect. It's very used to make fences and grills. For flat bar from to 6, 12 and 14mm.

For different sizes, please ask the manufacturer



Max. capacity	Min. capacity	Weight	PRICE
Square 14 mm	2x40 mm metal sheet	18Kg	722,00 €



Accessories for Horizontal Press Brake

Flat bar cutting tooling 100x10 mm.



Reference: 140-16-01-00014

Flat bar and metal sheet cutting die up to 100mm through a maximum thickness of 10mm in mild steel.



Max. Cutting length	Max. Cutting thickness	Weight	PRICE
100mm	10mm	23Kg	1.256,00 €

Tool to shape pipe ends PP200CNC

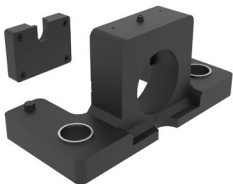

Reference: 140-16-01-00016

Basic die to modify the ends of the tubes for their assembly. You can make all kinds of shapes and flaps according to the customer needs.

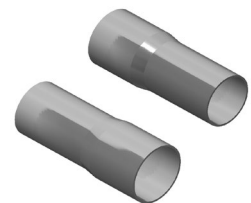

For special forms consult the manufacturer.

Weight: 110 Kg aprox. **PRICE:** **2.367,00 €**

Diameter reduction tools for PP200CNC

PP200CNC reduction cone

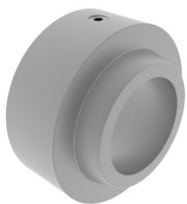

Reference: 140-16-01-RE001

This accessory is adapted to the **Tooling to shape pipe ends**, to perform the operation of reducing the ends of the tubes.

This accessory is used in all tube sizes, that is to say, it is not necessary to buy more than one since it is adaptable to all diameters.

Weight: 12,7 Kg. **PRICE:** **1.428,00 €**

Reducing clamp holder PP200CNC



Reference: 140-16-01-RE002

Accessory to set the **Reducing Clamps** of different diameters.

This accessory is used in all tube sizes, that is to say, it is not necessary to buy more than one since it is adaptable to all diameters.

Weight: 4,6 Kg. **PRICE:** **776,00 €**

Accessories for Horizontal Press Brake

PP200CNC reducer clamp



This accessory attaches to the **Reducing clamp holder**, to carry out the operation of reducing the ends of the tubes.

It is necessary to buy one specific reducing clamp for each tube according to its initial diameter and the final diameter that we want to achieve.

See the following table of Reducing Clamps:

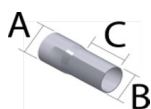

ØA max.	ØB min.	C max.	Reference	Description	PRICE
16mm	10mm	76mm	140-16-01-RE16-10	Tube Reducer Clamp 16-10 Length Max. 76mm	1.807,00 €
19mm	13mm	76mm	140-16-01-RE19-13	Tube Reducer Clamp 19-13 Length Max. 76mm	1.807,00 €
22mm	16mm	76mm	140-16-01-RE22-16	Tube Reducer Clamp 22-16 Length Max. 76mm	1.807,00 €
25mm	19mm	76mm	140-16-01-RE25-19	Tube Reducer Clamp 25-19 Length Max. 76mm	1.807,00 €
28mm	22mm	76mm	140-16-01-RE28-22	Tube Reducer Clamp 28-22 Length Max. 76mm	1.807,00 €
32mm	26mm	76mm	140-16-01-RE32-26	Tube Reducer Clamp 32-26 Length Max. 76mm	1.807,00 €
35mm	29mm	76mm	140-16-01-RE35-29	Tube Reducer Clamp 35-29 Length Max. 76mm	1.807,00 €
38mm	32mm	76mm	140-16-01-RE38-32	Tube Reducer Clamp 38-32 Length Max. 76mm	1.807,00 €
42mm	36mm	76mm	140-16-01-RE42-36	Tube Reducer Clamp 42-36 Length Max. 76mm	1.807,00 €
45mm	39mm	76mm	140-16-01-RE45-39	Tube Reducer Clamp 45-39 Length Max. 76mm	1.807,00 €
48mm	42mm	76mm	140-16-01-RE48-42	Tube Reducer Clamp 48-42 Length Max. 76mm	1.807,00 €
51mm	45mm	76mm	140-16-01-RE51-45	Tube Reducer Clamp 51-45 Length Max. 76mm	1.807,00 €
54mm	48mm	76mm	140-16-01-RE54-48	Tube Reducer Clamp 54-48 Length Max. 76mm	1.807,00 €
57mm	51mm	76mm	140-16-01-RE57-51	Tube Reducer Clamp 57-51 Length Max. 76mm	1.807,00 €
60mm	54mm	76mm	140-16-01-RE60-54	Tube Reducer Clamp 60-54 Length Max. 76mm	1.807,00 €
63mm	57mm	76mm	140-16-01-RE63-57	Tube Reducer Clamp 63-57 Length Max. 76mm	1.807,00 €
66mm	60mm	76mm	140-16-01-RE66-60	Tube Reducer Clamp 66-60 Length Max. 76mm	1.807,00 €
69mm	63mm	76mm	140-16-01-RE69-63	Tube Reducer Clamp 69-63 Length Max. 76mm	1.807,00 €
73mm	67mm	76mm	140-16-01-RE73-67	Tube Reducer Clamp 73-67 Length Max. 76mm	1.807,00 €

Accessories for Horizontal Press Brake

Diameter expansion tools PP200CNC

Clamp Holder to Expand Tube PP200CNC

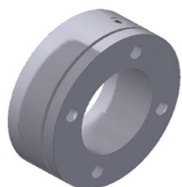

Reference: 140-16-01-EX001

This accessory is adapted to the **Tooling to shape pipe ends**, to perform the operation of expanding the ends of the tubes.

This accessory is used in all tube sizes, that is to say, it is not necessary to buy more than one since it is adaptable to all diameters.

PRICE: 1.390,00 €

Expansion Mandrel PP200CNC



Reference: 140-16-01-EX002

This accessory is adapted to the **Tooling to shape pipe ends**, to perform the operation of expanding the ends of the tubes.

This accessory is used in all tube sizes, that is to say, it is not necessary to buy more than one since it is adaptable to all diameters.

PRICE: 883,00 €

Tube Expander Clamp PP200CNC

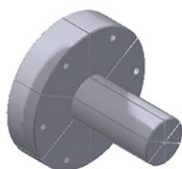

This accessory is adapted to the **Tooling to shape pipe ends**, to perform the operation of expanding the ends of the tubes.

It is necessary to buy one specific expanding clamp for each tube according to its initial diameter and the final diameter that we want to achieve.

See the following table of Expanding Clamps:

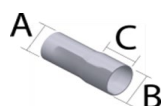

ØA min.	ØB max.	C max.	Reference	Description	PRICE
22mm	28mm	40mm	140-16-01-EX22-28	Tube Expander Clamp 22-28 Length Max. 40mm	1.197,00 €
25mm	31mm	40mm	140-16-01-EX25-31	Tube Expander Clamp 25-31 Length Max. 40mm	1.197,00 €
28mm	34mm	50mm	140-16-01-EX28-34	Tube Expander Clamp 28-34 Length Max. 50mm	1.197,00 €
31mm	37mm	60mm	140-16-01-EX31-37	Tube Expander Clamp 31-37 Length Max. 60mm	1.197,00 €
35mm	41mm	60mm	140-16-01-EX35-41	Tube Expander Clamp 35-41 Length Max. 60mm	1.197,00 €
38mm	44mm	65mm	140-16-01-EX38-44	Tube Expander Clamp 38-44 Length Max. 65mm	1.197,00 €
41mm	47mm	65mm	140-16-01-EX41-47	Tube Expander Clamp 41-47 Length Max. 65mm	1.197,00 €
44mm	50mm	80mm	140-16-01-EX44-50	Tube Expander Clamp 44-50 Length Max. 80mm	1.197,00 €
47mm	53mm	80mm	140-16-01-EX47-53	Tube Expander Clamp 47-53 Length Max. 80mm	1.197,00 €
51mm	57mm	80mm	140-16-01-EX51-57	Tube Expander Clamp 51-57 Length Max. 80mm	1.197,00 €
54mm	60mm	80mm	140-16-01-EX54-60	Tube Expander Clamp 54-60 Length Max. 80mm	1.197,00 €
60mm	66mm	80mm	140-16-01-EX60-66	Tube Expander Clamp 60-66 Length Max. 80mm	1.197,00 €

Accessories for Horizontal Press Brake

Die to straighten out profiles

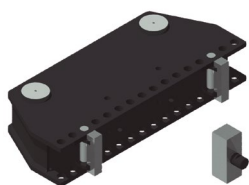

Reference: 140-16-01-00017

Tool used to bend straight profiles or parts. It is adjustable to different capacities according to the profiles.



Maximum capacity	Weight	PRICE
H 150 mm	72 Kg	1.399,00 €

Baluster forming die 20

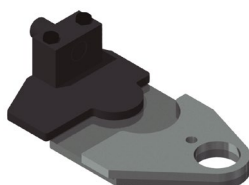

Reference: 140-16-01-00020

Die to form cold forging balusters for grills, gates, fences, handrails...

For other shapes or capacities, request the manufacturer.

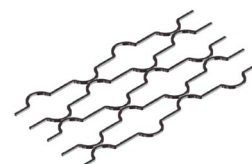

Square sizes	Circumference size	Weight	PRICE
12x12mm	90mm	11 Kg	589,00 €

Punching die

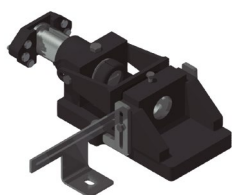

Reference: 140-16-01-00022

Punch-holder die, compatible with our Nargesa brand punches.

Gooseneck: 54 mm

Free distance of tooling: 95 mm

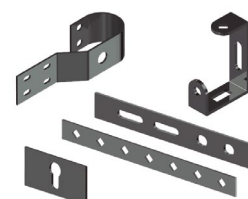

	Round	Square	Rectangular	Oval	Weight	PRICE
Max. Punching capacity	43mm	35mm	20x34mm	21x40mm	52 Kg	2.324,00 €

Promecam punch holder

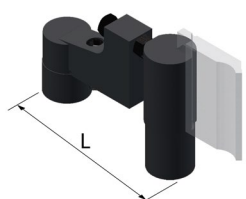

Reference: 140-16-01-00023

Punch holder for all kind of punches for Promecam bending or folding press.

Compatible with any Promecam punch.



Max. Folding length	L Length	Weight	PRICE
161mm	276 mm	14kg	616,00 €

Accessories for Horizontal Press Brake

Inverted Promecam-holder PP200CNC

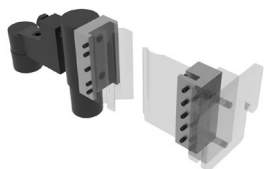

Reference: 140-16-01-00039

Punch holder for all kind of punches for Promecam bending or folding press with inverted position.

Compatible with any Promecam punch.

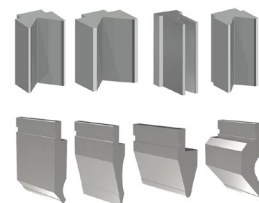

Max. Folding length	Weight	PRICE
161mm	19,8kg	1.016,00 €

Clamp forming die PP200CNC



Reference: 140-16-01-00024

Die to form all kinds of clamps. This tooling is manufactured according to the user's needs thus it is required to have a technical drawing or a sample piece.

Maximum capacity: 100x4 mm



Special punches

Folding punches to bend special pieces of small sizes or folded up to 30°.

Folding Punch P.70.30.R1

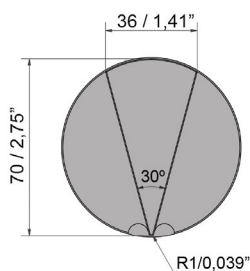

Reference: 140-16-01-00025

Max. Folding length: 100mm

Punch degrees: 30°

Punch diameter: 70mm

Weight: 3 Kg.

PRECIO: 285,00 €

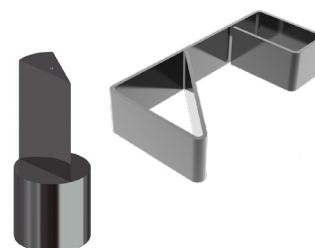

Folding Punch P.40.80.R1

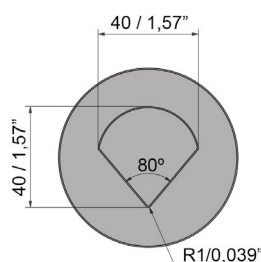

Reference: 140-16-01-00026

Max. Folding length: 60mm

Punch degrees: 80°

Punch diameter: 40mm

Weight: 3 Kg.

PRECIO: 285,00 €

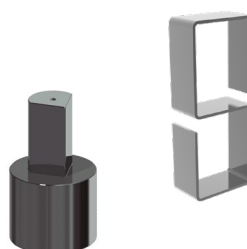

Accessories for Horizontal Press Brake

Folding Punch P.22.80.R1

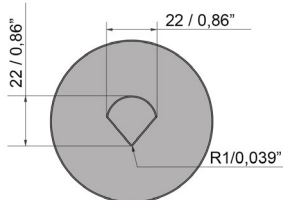

Reference: 140-16-01-00027

Max. Folding length: 60mm

Punch degrees: 80°

Punch diameter: 22mm

Weight: 3 Kg.

PRICE: 285,00 €

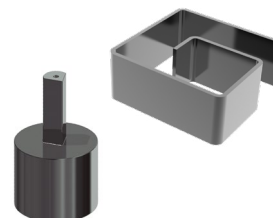

Folding Punch P.70.80.R5

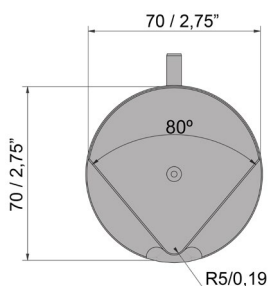

Reference: 140-16-01-00080

Max. Folding length: 100 mm

Punch degrees: 80°

Punch diameter: 70 mm

Weight: 3 Kg.

PRICE: 285,00 €

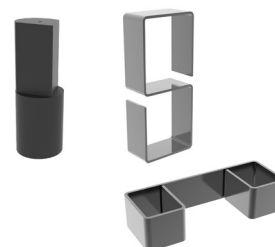

Bar clamps forming die

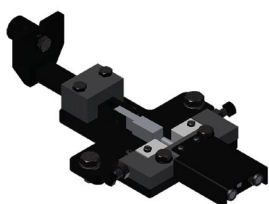

Reference: 140-16-01-00028

Clamp forming die, used to manufacture the clamps used to join different forging bars with no need to get them welded.



Max. capacity	Weight	PRICE
25x5mm	9Kg	675,00 €

Forming die adaptor



Reference: 140-16-01-00029

It is an exchangeable fitting device for the forming dies, suitable for each of the different baluster forming tools. It is advisable to get one in order to work with the specified dies.

Weight: 3,1 Kg.

PRICE: 92,00 €



Accessories for Horizontal Press Brake

Punch Promecam PS.135.85.R08

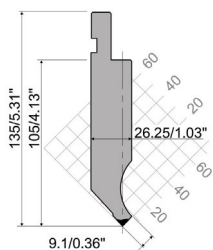

Reference: 140-16-01-00030

Folding length: 161 mm

Weight: 3,2 Kg.

PRICE: **226,00 €**

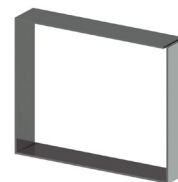

Punch Promecam P.95.35.R5

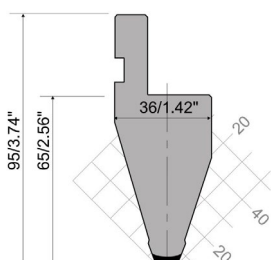

Referencia: 140-16-01-00031

Folding length: 161 mm

Weight: 2,3 Kg.

PRICE: **241,00 €**

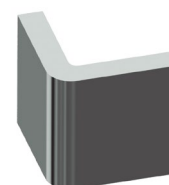

Punch Promecam PS.134.30.R08

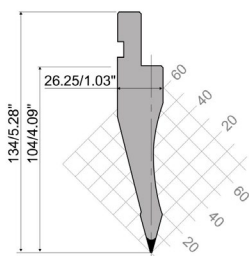

Reference: 140-16-01-00032

Folding length: 161 mm

Weight: 2,7 Kg.

PRICE: **252,00 €**



Punch Promecam PK.135.85.R08

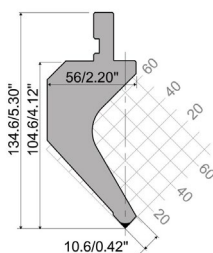

Reference: 140-16-01-00038

Folding length: 161 mm

Weight: 4,4 Kg.

PRICE: **305,00 €**



Accessories for Horizontal Press Brake

Folding die M75.85.63

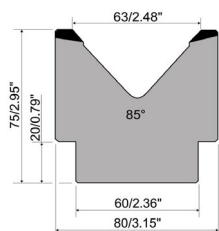

Reference: 140-16-01-00033
Folding length: 161 mm Max. 85°
 V63: From 5 to 10 mm sheet
Weight: 5 Kg.
PRICE: 295,00 €

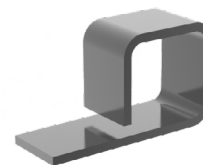

Folding die M80.85.80

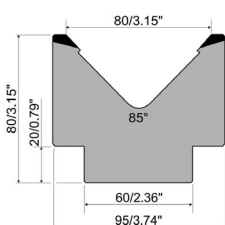

Reference: 140-16-01-00034
Folding length: 161 mm Max. 85°
 V80: From 6 to 12 mm sheet
Weight: 6 Kg.
PRICE: 338,00 €

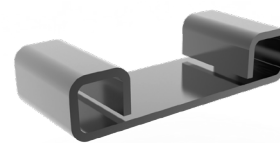

Folding die M95.80.100

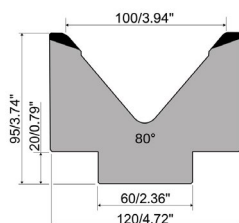

Reference: 140-16-01-00035
Folding length: 161 mm Max. 80°
 V100: From 8 to 15 mm sheet
Weight: 9 Kg.
PRICE: 370,00 €

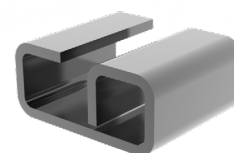

Folding die T80.25.35

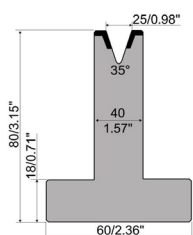

Reference: 140-16-01-00036
Folding length: 161 mm Max. 35°
 V25: From 1,5 to 5 mm sheet
Weight: 4 Kg.
PRICE: 252,00 €





Accessories for Horizontal Press Brake

Folding die MK103.80.125

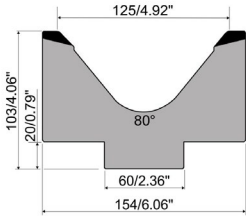

Reference: 140-16-01-00040
Folding length: 161 mm Max. 80°
V125: From 12 to 20 mm sheet
Weight: 12,4 Kg.
PRICE: 545,00 €



Folding die M80.45.40

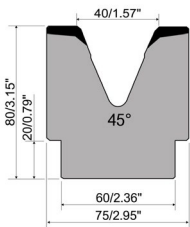

Reference: 140-16-01-00041
Folding length: 161 mm Max. 45°
V40: From 3 to 8 mm sheet
Weight: 6,2 Kg.
PRICE: 327,00 €

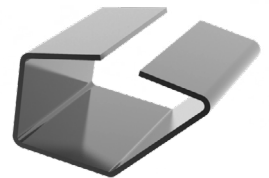

Accessories for Horizontal Press Brake

Small radii holder PU.67.14-S



Reference: 140-16-01-00042

European style R1 bending tool holder. (For radii from 3 to 7,5 mm)

Folding length: 161 mm

Weight: 2 Kg.

PRICE: 332,00 €

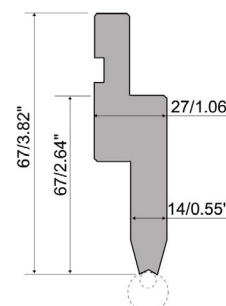

Radius elements for small radii holders PU.67.14-S

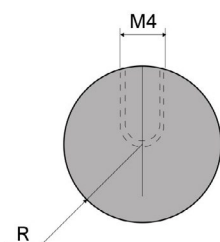

Radius elements to fold. Made of C45, a high quality, medium grade steel, with constant mechanical properties and good external chrome resistance.

Maximum capacity: 400kN/m.

Tonnage: 400 kN/m max.

For its use it requires the PU.67.14-S Small radius holder.

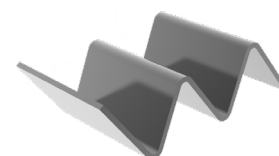

Please refer to the following radius chart:

Small Radius					
Type	Code	Reference	Radius	Weight	PRICE
C3	PU.67.14-S-C3	140-16-01-00044	3 mm	0,04 Kg.	75,00 €
C3.5	PU.67.14-S-C3.5	140-16-01-00045	3,5 mm	0,04 Kg.	78,00 €
C4	PU.67.14-S-C4	140-16-01-00046	4 mm	0,07 Kg.	80,00 €
C4.5	PU.67.14-S-C4.5	140-16-01-00047	4,5 mm	0,10 Kg.	83,00 €
C5	PU.67.14-S-C5	140-16-01-00048	5 mm	0,12 Kg.	86,00 €
C5.5	PU.67.14-S-C5.5	140-16-01-00049	5,5 mm	0,14 Kg.	94,00 €
C6	PU.67.14-S-C6	140-16-01-00050	6 mm	0,16 Kg.	96,00 €
C6.5	PU.67.14-S-C6.5	140-16-01-00051	6,5 mm	0,20 Kg.	98,00 €
C7	PU.67.14-S-C7	140-16-01-00052	7 mm	0,16 Kg.	96,00 €
C7.5	PU.67.14-S-C7.5	140-16-01-00053	7,5 mm	0,20 Kg.	98,00 €

Accessories for Horizontal Press Brake

Big radii holder PU.67.14

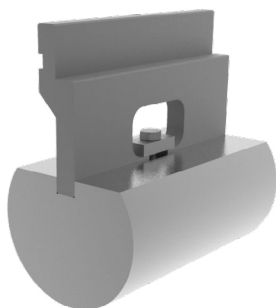

Reference: 140-16-01-00043

European style R1 bending tool holder. (For radii from 8 to 50 mm)

Folding length: 161 mm

Weight: 1,80 Kg.

PRICE: 239,00 €

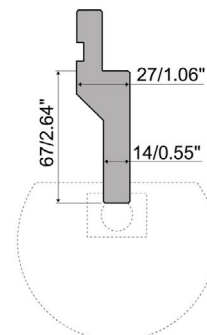

Radius elements for large radii holders PU.67.14

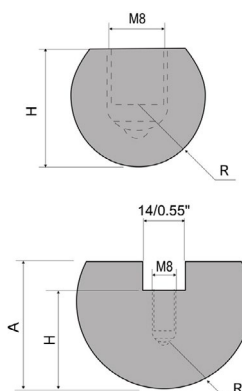

Radius elements to fold. Made of C45, a high quality, medium grade steel, with constant mechanical properties and good external chrome resistance.

Tonnage: 800 kN/m max.

For its use it requires the PU67.14 large radius holder.

Please refer to the following radius chart:

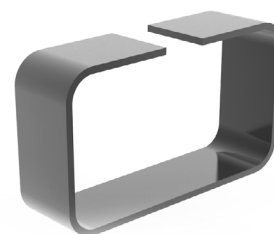

Big Radius						
Code	Reference	R (mm)	H (mm)	A (mm)	Weight	PRICE
PU.67.14.R8	140-16-01-00054	8	13	-	0,04 Kg.	81,00 €
PU.67.14.R9	140-16-01-00055	9	16	-	0,04 Kg.	81,00 €
PU.67.14.R10	140-16-01-00056	10	16	-	0,04 Kg.	70,00 €
PU.67.14.R12,5	140-16-01-00057	12,5	17	22	0,50 Kg.	112,00 €
PU.67.14.R15	140-16-01-00058	15	20	27	0,75 Kg.	97,00 €
PU.67.14.R17,5	140-16-01-00059	17,5	22	32	1,00 Kg.	139,00 €
PU.67.14.R20	140-16-01-00060	20	24	34	1,40 Kg.	119,00 €
PU.67.14.R22,5	140-16-01-00061	22,5	25	35	1,50 Kg.	124,00 €
PU.67.14.R25	140-16-01-00062	25	29	39	2,00 Kg.	129,00 €
PU.67.14.R27,5	140-16-01-00063	27,5	34	44	2,50 Kg.	139,00 €
PU.67.14.R30	140-16-01-00064	30	34	44	2,70 Kg.	157,00 €
PU.67.14.R32,5	140-16-01-00065	32,5	37	47	3,20 Kg.	235,00 €
PU.67.14.R35	140-16-01-00066	35	45	55	4,10 Kg.	315,00 €
PU.67.14.R37,5	140-16-01-00067	37,5	42	52	4,10 Kg.	337,00 €
PU.67.14.R40	140-16-01-00068	40	45	55	4,60 Kg.	361,00 €
PU.67.14.R45	140-16-01-00069	45	60	70	6,80 Kg.	436,00 €
PU.67.14.R50	140-16-01-00070	50	70	80	8,70 Kg.	457,00 €

Accessories for Horizontal Press Brake

Punches and dies

Standard round punches

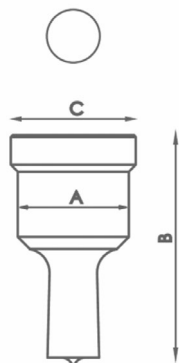

Type	Available sizes in mm Ø	A	B	C	PRICE
N28	3/3'5/4/4'5/5/5'5/6/6'5/7/7'5/8/8'5 9mm up to 28mm from 0'5 in 0'5mm	28 mm	58 mm	31,5 mm	22,00 €/uni
N40	29/30/31/32/33/34/35/36/37/38/39/40mm	40 mm	64 mm	43,5 mm	32,00 €/uni
N50	41/42/43mm	50 mm	58 mm	54 mm	105,00 €/uni

For different sizes, please ask the manufacturer

Standard square punches

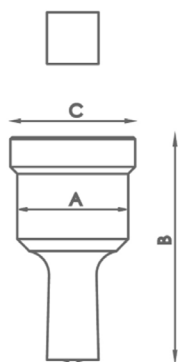

Type	Available sizes in mm	A	B	C	PRICE
N28	4/5/6/7/8/9/10/11/12/13/14/15/16/17 18/19/20mm	28 mm	58 mm	31,5 mm	42,00 €/uni
N40	21/22/24/26/28mm	40 mm	64 mm	43,5 mm	73,00 €/uni
N50	31/33/35mm	50 mm	58 mm	54 mm	135,00 €/uni

For different sizes, please ask the manufacturer

Standard rectangular punches

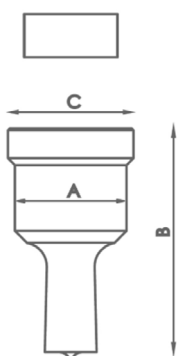

Type	Available sizes in mm	A	B	C	PRICE
N28	7x10/7x15/9x13/9x19/11x17/11x23 13x19/15x21mm	28 mm	58 mm	31,5 mm	42,00 €/uni
N40	13x25/15x27/17x25/19x30/20x34mm	40 mm	64 mm	43,5 mm	73,00 €/uni

For different sizes, please ask the manufacturer

Accessories for Horizontal Press Brake

Standard oval punches

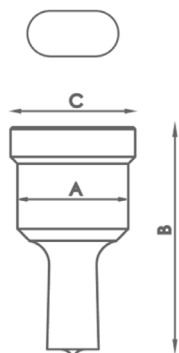

Type	Available sizes in mm	A	B	C	PRICE
N28	7x10/7x15/7x20/9x13/9x19/11x17/11x23 11x27/13x18 /13x22/13x27/15x20/15x24 15x27/17x22/17x26 19x26/21x27mm	28 mm	58 mm	31,5 mm	42,00 €/uni
N40	13x31/15x31/17x31/17x40/19x31 19x40/21x31/21x40mm	40 mm	64 mm	43,5 mm	73,00 €/uni
<i>For different sizes, please ask the manufacturer</i>					

Standard round dies

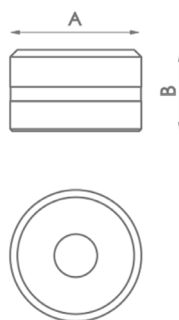

Type	Available sizes in mm Ø	A	B	PRICE
N46	3/3,5/4/4,5/5/5,5/6/6,5/7/7,5/8/8,5 9mm up to 28mm from 0,5 in 0,5mm	46 mm	28,5 mm	17,00 €/uni
N60	29/30/31/32/33/34/35/36/37/38/39/40mm	60 mm	32 mm	21,00 €/uni
N78	41/42/43mm	78 mm	28,5 mm	86,00 €/uni
<i>For different sizes, please ask the manufacturer</i>				

Standard square dies

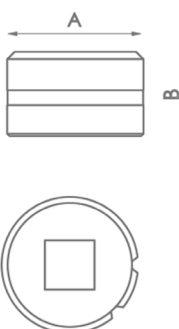

Type	Available sizes in mm	A	B	PRICE
N46	4/5/6/7/8/9/10/11/12/13/14/15/16 17/18/19/20mm	46 mm	28,5 mm	50,00 €/uni
N60	21/22/24/26/28mm	60 mm	32 mm	58,00 €/uni
N78	31/33/35mm	78 mm	28,5 mm	128,00 €/uni
<i>For different sizes, please ask the manufacturer</i>				

Accessories for Horizontal Press Brake

Standard rectangular dies

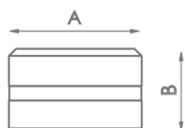

Type	Available sizes in mm	A	B	PRICE
N46	7x10/7x15/9x13/9x19/11x17/11x23/ 13x19/13x25/ 15x21mm	46 mm	28,5 mm	50,00 €/uni
N60	15x27/17x25/19x30/20x34mm	60 mm	32 mm	58,00 €/uni

For different sizes, please ask the manufacturer

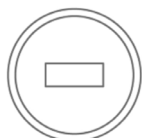

Oval dies



Type	Available sizes in mm	A	B	PRICE
N46	7x10/7x15/7x20/9x13/9x19/11x17/11x23 11x27/13x18/13x22/13x27/15x20/15x24/15x27 17x22/17x26/19x26/21x27mm	46 mm	28,5 mm	32,00 €/uni
N60	13x31/15x31/17x31/17x40/19x31 19x40/21x31/21x40mm	60 mm	32 mm	41,00 €/uni

For different sizes, please ask the manufacturer



Tube notching tooling

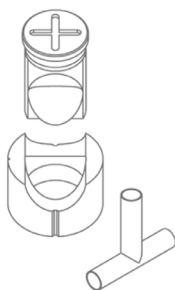

Reference	Available sizes in mm	Required fitting		PRICE
MAN28	Tube from 16 to 28mm	TAP 28	CAB 46	269,00 €/uni
MAN40	Tube from 28,5 to 40mm	TAP 40	CAB 60	340,00 €/uni
MAN50	Tube from 40,5 to 50mm	TAP 50	CAB 78	413,00 €/uni

For different sizes, please ask the manufacturer

Accessories for Horizontal Press Brake

Flat bar round end tooling R1

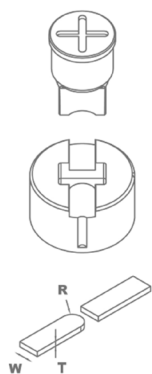

Reference	Model	Width size	Required fitting	PRICE
MOR1-35A	A	From 20 to 35mm	TAP28 / TAP40	459,00 €/uni
MOR1-35B	B	From 20 to 35mm	TAP28 / TAP40	595,00 €/uni
MOR1-35C	C	From 20 to 35mm	TAP28 / TAP40	595,00 €/uni
MOR1-35D	D	From 20 to 35mm	TAP28 / TAP40	690,00 €/uni
MOR1-50A	A	From 40 to 50mm	TAP50 / TAP60 with ATAP	495,00 €/uni
MOR1-50B	B	From 40 to 50mm	TAP50 / TAP60 with ATAP	619,00 €/uni
MOR1-50C	C	From 40 to 50mm	TAP50 / TAP60 with ATAP	619,00 €/uni
MOR1-50D	D	From 40 to 50mm	TAP50 / TAP60 with ATAP	733,00 €/uni

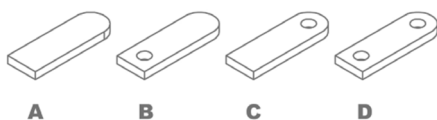

For different sizes, please ask the manufacturer.
 When placing order it must be specified the REFERENCE, MODEL, R (radius), W (flat bar width), T (flat bar thickness)
 In models B, C and D specify diameter of the hole.
 The ear shaped legth is always adjustable.
 Production capacity: 450 to 600 parts per hour.

Flat bar round end tooling R2

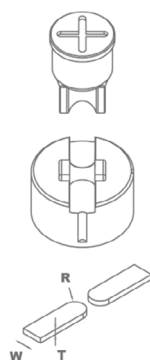

Reference	Model	Width size	Required fitting	PRICE
MOR2-35A	A	From 20 to 35mm	TAP28 / TAP40	459,00 €/uni
MOR2-35B	B	From 20 to 35mm	TAP28 / TAP40	595,00 €/uni
MOR2-35C	C	From 20 to 35mm	TAP28 / TAP40	690,00 €/uni
MOR2-50A	A	From 40 to 50mm	TAP50 / TAP60 with ATAP	495,00 €/uni
MOR2-50B	B	From 40 to 50mm	TAP50 / TAP60 with ATAP	619,00 €/uni
MOR2-50C	C	From 40 to 50mm	TAP50 / TAP60 with ATAP	733,00 €/uni

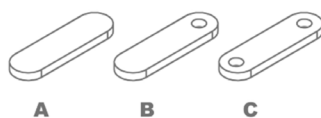

For different sizes, please ask the manufacturer.
 When placing order it must be specified the REFERENCE, MODEL, R (radius), W (flat bar width), T (flat bar thickness)
 In models B and C specify hole diameter.
 The ear shaped legth is always adjustable.
 Production capacity: 450 to 600 parts per hour.

Accessories for Horizontal Press Brake

Corner rounding tooling



Reference	Available sizes in mm	Required fitting		PRICE
MRE28	Radius from 3 to 15mm	TAP 28	CAB 46	275,00 €/uni
MRE40	Radius from 16 to 26mm	TAP 40	CAB 60	393,00 €/uni
MRE50	Radius from 26,5 to 32mm	TAP 50	CAB 78	446,00 €/uni

For different sizes, please ask the manufacturer

Fitting nuts for punches

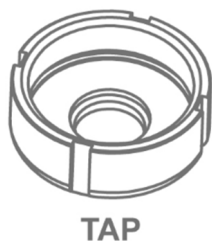

Reference	Type	Fitting nuts for punches	PRICE
120-02-01-00011	TAP28	Fitting nuts for punches N28	87,00 €
140-02-01-00019	TAP40	Fitting nuts for punches N40	87,00 €
140-02-01-00020	TAP50	Fitting nuts for punches N50	87,00 €
140-02-01-00021	TAP60	Fitting nuts for punches N60	87,00 €

Fitting for dies



Reference	Type	Fitting for dies	PRICE
120-02-01-00012	N46	Fitting for dies N46	60,00 €
140-02-01-00024	N60	Fitting for dies N60	60,00 €
140-02-01-00025	N78	Fitting for dies N78	60,00 €



PP200CNC Folding simulator software

PP200CNC Folding simulator software

The new bending simulator for the PP200CNC Horizontal Press Brake is the ultimate tool for **manufacturers and operators aiming to maximize productivity and precision.**

Developed for **Windows**, it is offered as a **perpetual license**—no monthly or annual subscriptions—and allows users to create bending programs in numeric or graphical mode remotely from a PC, without tying up the machine or an operator.

Offline Programming: Load a technical drawing (DXF or similar) and the software automatically recognizes bend lines to generate a complete CNC program.

Manual Programming: Very simple and intuitive—get a program for a highly complex part in under 3 minutes.

Direct USB Export: Save the program to a USB stick, import it into the PP200CNC, and start producing immediately.

Automatic Calculations with hundredth-millimeter precision: From a drawing or manual inputs, the simulator computes the flat blank, final inside radius, minimum tonnage, backgauge positions, and the best manufacturing strategy.

Collision Analysis: Detects and prevents possible collisions among tool, machine, and part during bending, ensuring feasibility and safety.

Bending Process Optimizer: Automatically calculates parameters such as part orientation and bend angle based on material and final-part characteristics.

Backgauge Sequencer: Determines the exact backgauge position at each step. If no automatic backgauge is available, the software guides the operator on the required positions.

Virtual Simulation: Simulates the bending process virtually, showing positions and potential collisions clearly.

Sequence Optimization: Optimizes bend order via 2D graphical generation and adjusts parameters to provide the most efficient and safe sequence for the operator.

Intuitive Interface: A very user-friendly graphical UI that speeds configuration and simulation.

Multi-Machine Compatibility: Works with different brands and models of press brakes.

Ideal for Training: Practice and assess bending processes in a virtual environment without stopping real machines, reducing risk, material use, and classroom setup time.

NEW

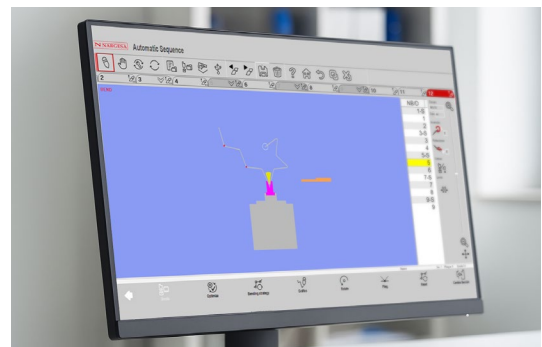

Reference	140-16-OP-00001
PRICE	990,00 €

Shears

Hydraulic shears C2006CNC

NEW vertical cut shears C2006CNC Nargesa, from the latest generation, are made with stabilized and welded steel which per-mits to stand big effort with no deformation.

Reference	100-06-01-001
Engine power	5,87 KW / 7,87 HP
Three-phased tension	230 / 400 V
Cutting Capacity: mild steel	6 mm (450N/mm2)
Cutting capacity: stainless steel	4 mm (700N/mm2)
Nº of hammers	10 units
Cutting length	2030 mm
Neck	190 mm
Gauge displacement	700 mm
Strokes per minute	10 strokes
Position accuracy and repeatability	+/- 0,1 mm
Dimensions	2880x2360x1790 mm
Weight	5100 Kg
PRICE	29.749,00 €



Nargesa hydraulic Shears are controlled with a very intuitive and easy-to-use 7" color touchscreen with the latest 4.0 technology. **The operator only has to enter the type of material, thickness, distance from the gauge and the CNC will automatically arrange all components to obtain an optimal result.**

Can manage up 3 axes and 16+ 12 I/O with an integrated PLC.

Shears

Hydraulic shears C3006CNC

NEW vertical cut shears C3006CNC Nargesa, from the latest generation, are made with stabilized and welded steel which per-mits to stand big effort with no deformation.

Reference	100-06-02-003
Engine power	9,6 KW / 12,87 HP
Three-phased tension	230 / 400 V
Cutting Capacity: mild steel	6 mm (450N/mm2)
Cutting capacity: stainless steel	4 mm (700N/mm2)
Nº of hammers	15 units
Cutting length	3055 mm
Neck	173 mm
Gauge displacement	700 mm
Strokes per minute	12 strokes
Position accuracy and repeatability	+/- 0,1 mm
Dimensions	3880x2460x1820 mm
Weight	7500 Kg
PRICE	40.656,00 €

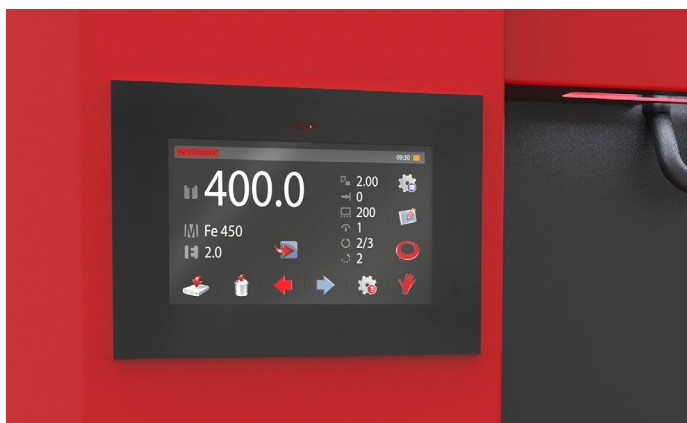

Nargesa hydraulic Shears are controlled with a very intuitive and easy-to-use 7" color touchscreen with the latest 4.0 technology. **The operator only has to enter the type of material, thickness, distance from the gauge and the CNC will automatically arrange all components to obtain an optimal result.**

Can manage up 3 axes and 16+ 12 I/O with an integrated PLC.

Press Brakes

Hydraulic press brake MP1500CNC

The hydraulic sheet metal brake MP1500CNC Nargesa, from the last generation, has been made of welded and stabilized steel which permits it to stand big efforts without any kind of distortion.

Reference	100-05-09-001
Engine Power	5,5 KW / 7,5 HP
Three-Phased tension	230 / 400 V
Hydraulic power	40 Tn
Punch working speed	8,3 mm/s
Punch return speed	120 mm/s
Punch lowering speed	200 mm/s
Max. Punch displacement	200 mm
Inner folding length	1250 mm
Total folding length	1500 mm
Back gauge displacement	600 mm
Neck	270 mm
Dimensions	2110x1880x2210 mm
Weight	4900 Kg
PRICE	50.069,00 €



The powerful ESA S630 CNC control system has outstanding processing capacity which permits up to four axes to be managed, interpolated in any combination Y, X, R and Z, providing solutions for the most complex bending operations, and a flash memory for 5000 programs and a full library of Promecam punches and dies.

The 10" high-resolution (1024 x 600 pixels) colour graphics touch screen responds efficiently to user operations and provides clear and detailed information at all times. It enables programs to be edited graphically or numerically, new dies and punches to be managed, edited and added to existing libraries, bending sequences to be controlled, bending collisions to be controlled, bending simulations to be done, sheet metalwork to be calculated and machine sensors and inputs/outputs to be diagnosed in an intuitive and straightforward manner

Press Brakes

Hydraulic press brake MP3160CNC

The hydraulic sheet metal brake MP3160CNC Nargesa, from the last generation, has been made of welded and stabilized steel which permits it to stand big efforts without any kind of distortion.

Reference	100-05-10-001
Engine Power	15 KW / 20 CV
Three-Phased tension	230 / 400 V
Hydraulic power	160 Tn
Punch working speed	9 mm/s. 0,35" /s.
Punch return speed	97 mm/s. 3,84" /s.
Punch lowering speed	200 mm/s. 7,88" /s.
Max. Punch displacement	220mm. 8,66"
Free distance table/slice	445mm. 17,52"
Inner folding length	2630mm. 103,5"
Total folding length	3100mm. 122"
Back gauge displacement	600+100mm. 23,62" +4"
Neck	400mm. 15,75"
Dimensions	3751x1997x2585 mm
Weight	11.900 Kg
PRICE	70.940,00 €



NEW

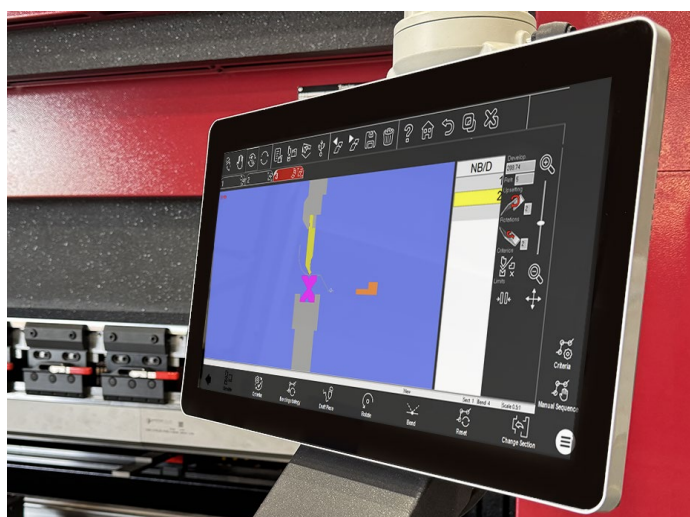

ESA numerical control S840W

- Microsoft Windows operating system
- PC simulator and optimizer for 2D and 3D graphic identification and programming of the fastest and most reliable bending sequences.
- CNC simulator and optimizer for 2D graphic identification and programming of the fastest and most reliable bending sequences.
- Connectivity with EsaBend 3D CadCam (Optional)
- Completely intuitive operating system
- Real-time program and tool file explorer
- Local and remote self-diagnosis system
- Alarm and warning system for preventive maintenance
- Multi-language
- 15.6" HD LCD touchscreen with GlassOnly technology
- Industry 4.0
- Multiple ports: USB, Ethernet, EtherCAT, CanBus
- Metric and Imperial systems



Accessories for Press Brakes

R axis

The R Axis is not supplied as standard with the machine; the client may include it when purchasing the machine or add it later. This Axis has a Canopen communication system that enables it to be installed in a rapid and simple manner to the machine. The operator needs only to connect it to the motor of the X axis and Nargesa's technicians will configure the CNC remotely.

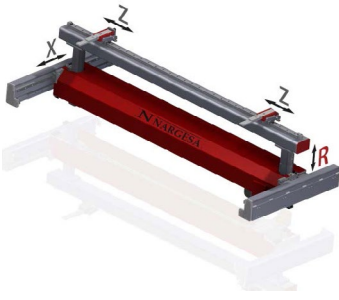

Reference	140-05-OP-00001
High speed measurement search	130 mm/sec.
Servo motor	1 Nm to 5000 rpm
R axis limit	150 mm
Mechanical precision	0,05 mm
PRICE	4.275,00 €

Graphs and folding calculation on CNC

The user can incorporate the optional software on the press brake CNC and buy it later on. There is also the possibility of carrying out the remote software installation, by our Nargesa Technicians.

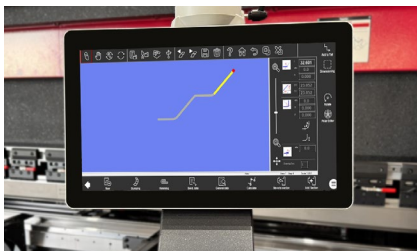

Reference	140-05-OP-00002
PRICE	1.871,00 €

Z1-Z2 axis

The Z1-Z2 axis enables us to optimize the set up time of the machine. The CNC optimizes the position of gauges Z1 and Z2 according to the dimensions of the piece and the position of the tools.

The parallelism of the gauge needles with the folding unit of the press brake fits automatically by means of micrometers to guarantee the maximum accuracy.

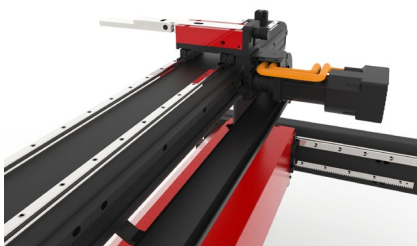

Reference	140-05-OP-00004
High search speed of size	400 mm/sec.
Linear guides for recirculation of high precision balls	
Servo motors	1 Nm a 5000 rpm
Stroke axis Z1, Z2	2600 mm
Mechanical precision	0,05 mm
PRICE	12.552,00 €

* In case of choosing this option the machine will be delivered with the ESA 640 CNC,

* This option is only available if you have chosen the following optional accessories: R-axis and Graphics and CNC bending calculation

Accessories for Press Brakes

Punches

All accessories for Nargesa Pres Brakes are manufactured according to international standards. Therefore, guaranteeing high resilience and tensile strength. *For different sizes, please ask the manufacturer.*

Material Type	Mechanical resistance of the material and the tool body	Hardness of the material and the tool body	Hardness of the operating surfaces after induction hardening
● C45	560 - 710 N/mm ²	12 - 15.5 HRC	54 - 60 HRC

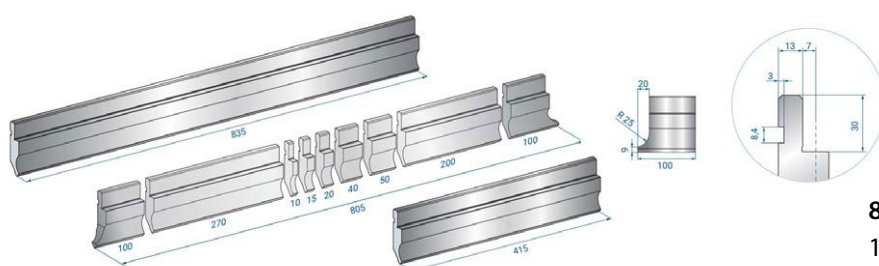

805 mm segmented

100, 370, 10, 15, 20, 40, 50, 100, 100 mm

*Conversion millimeters / inches:

415 mm / 16,34"

805 mm / 31,69"

835 mm / 32,87"

● PU.85.35.R08 - 1034

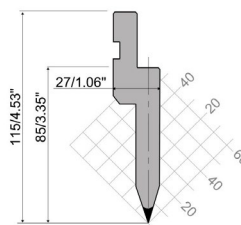

Length	PRICE
835 mm.	211,00 €
415 mm.	126,00 €
805 mm. Seg.	350,00 €

● P.95.35.R5

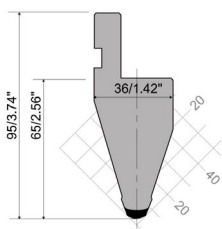

Length	PRICE
835 mm.	312,00 €
415 mm.	195,00 €
805 mm. Seg.	477,00 €

● P.120.35.R08 - 1047

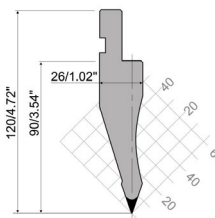

Length	PRICE
835 mm.	222,00 €
415 mm.	127,00 €
805 mm. Seg.	359,00 €

● P.120.35.R15 - 1282

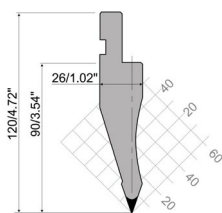

Length	PRICE
835 mm.	216,00 €
415 mm.	120,00 €
805 mm. Seg.	346,00 €

● P.130.85.R025 - 1262 MOD85°

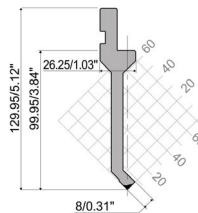

Length	PRICE
835 mm.	394,00 €
415 mm.	220,00 €
805 mm. Seg.	558,00 €

Accessories for Press Brakes

● PK.135.85.R08 - 1172

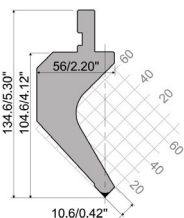

Length	PRICE
835 mm.	383,00 €
415 mm.	212,00 €
805 mm. Seg.	525,00 €

● PS.135.85.R08 - 1281

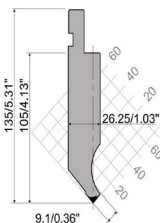

Length	PRICE
835 mm.	310,00 €
415 mm.	179,00 €
805 mm. Seg.	471,00 €

Dies

For different sizes, please ask the manufacturer.

Material Type	Mechanical resistance of the material and the tool body	Hardness of the material and the tool body	Hardness of the operating surfaces after induction hardening
● C45	560 - 710 N/mm ²	12 - 15.5 HRC	54 - 60 HRC

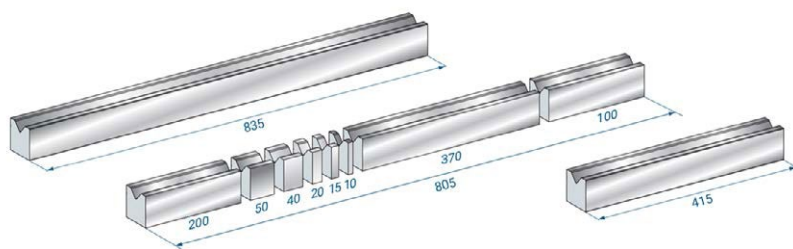

805 mm segmented
100, 370, 10, 15, 20, 40, 50, 200 mm

● M.460.R - 2067

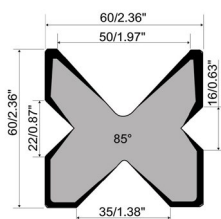

Length	PRICE
835 mm.	318,00 €
415 mm.	189,00 €
805 mm. Seg.	494,00 €

● M.460.60 - 2034

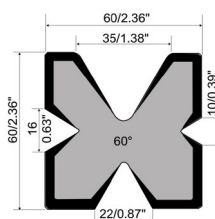

Length	PRICE
835 mm.	444,00 €
415 mm.	260,00 €
805 mm. Seg.	625,00 €

● T80.06.35

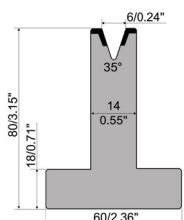

Length	PRICE
835 mm.	439,00 €
415 mm.	266,00 €
805 mm. Seg.	643,00 €

● T80.06.85 - 3086

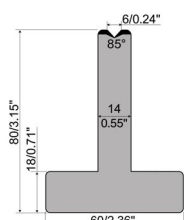

Length	PRICE
835 mm.	287,00 €
415 mm.	170,00 €
805 mm. Seg.	442,00 €

Accessories for Press Brakes

• T80.08.35

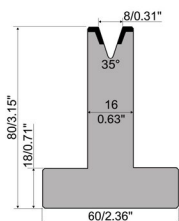

Length	PRICE
835 mm.	439,00 €
415 mm.	266,00 €
805 mm. Seg.	643,00 €

• T80.08.85 - 3087

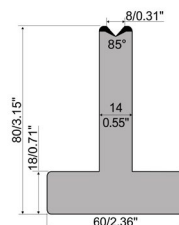

Length	PRICE
835 mm.	287,00 €
415 mm.	170,00 €
805 mm. Seg.	442,00 €

• T80.10.35

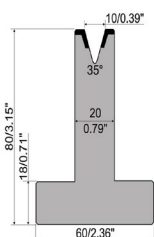

Length	PRICE
835 mm.	439,00 €
415 mm.	266,00 €
805 mm. Seg.	643,00 €

• T80.10.85 - 3088

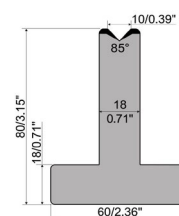

Length	PRICE
835 mm.	287,00 €
415 mm.	170,00 €
805 mm. Seg.	442,00 €

• T80.12.35

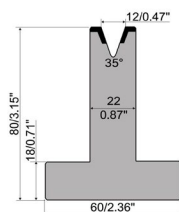

Length	PRICE
835 mm.	439,00 €
415 mm.	266,00 €
805 mm. Seg.	643,00 €

• T80.12.85 - 3089

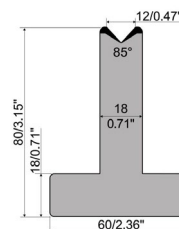

Length	PRICE
835 mm.	287,00 €
415 mm.	170,00 €
805 mm. Seg.	442,00 €

• T80.16.35

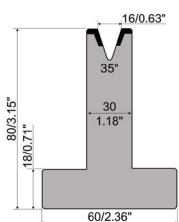

Length	PRICE
835 mm.	459,00 €
415 mm.	274,00 €
805 mm. Seg.	672,00 €

• T80.16.85 - 3090

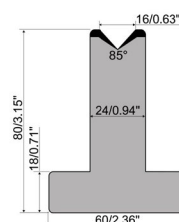

Length	PRICE
835 mm.	287,00 €
415 mm.	170,00 €
805 mm. Seg.	442,00 €

• T80.20.35

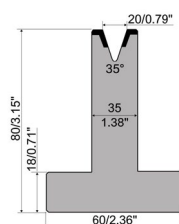

Length	PRICE
835 mm.	459,00 €
415 mm.	274,00 €
805 mm. Seg.	672,00 €

• T80.20.85 - 3091

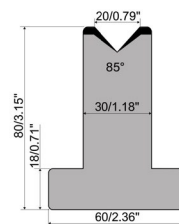

Length	PRICE
835 mm.	287,00 €
415 mm.	170,00 €
805 mm. Seg.	442,00 €



Accessories for Press Brakes

• T80.25.35

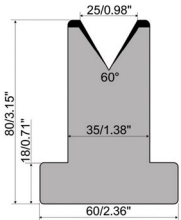

Length	PRICE
835 mm.	459,00 €
415 mm.	274,00 €
805 mm. Seg.	672,00 €

• T80.25.85 - 3092

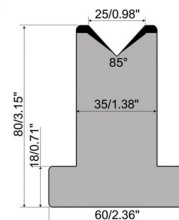

Length	PRICE
835 mm.	287,00 €
415 mm.	170,00 €
805 mm. Seg.	442,00 €

• M75.85.63 - 2023

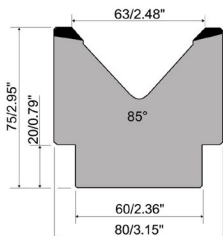

Length	PRICE
835 mm.	369,00 €
415 mm.	219,00 €
805 mm. Seg.	582,00 €

• M80.45.32 - 2088

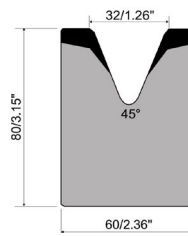

Length	PRICE
835 mm.	328,00 €
415 mm.	188,00 €
805 mm. Seg.	504,00 €

• M80.45.40 - 2081

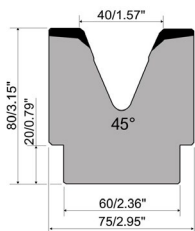

Length	PRICE
835 mm.	498,00 €
415 mm.	279,00 €
805 mm. Seg.	698,00 €

• M80.85.80 - 2024

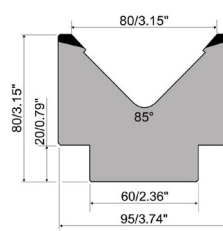

Length	PRICE
835 mm.	496,00 €
415 mm.	289,00 €
805 mm. Seg.	729,00 €

• M86.60.63 - 2083

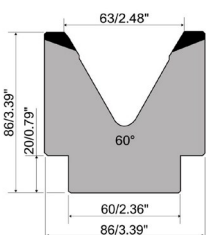

Length	PRICE
835 mm.	705,00 €
415 mm.	371,00 €
805 mm. Seg.	991,00 €

• M95.80.100 - 2025

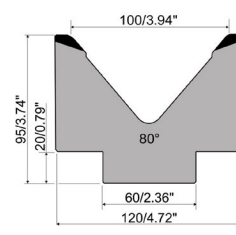

Length	PRICE
835 mm.	588,00 €
415 mm.	337,00 €
805 mm. Seg.	889,00 €

• MK103.80.125 - 2026

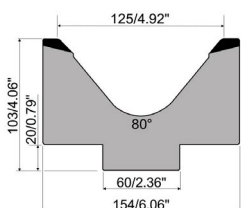

Length	PRICE
835 mm.	741,00 €
415 mm.	420,00 €
805 mm. Seg.	1.099,00 €

• M110.60.80 - 2089

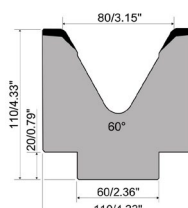

Length	PRICE
835 mm.	1.051,00 €
415 mm.	592,00 €
805 mm. Seg.	1.487,00 €



Accessories for Press Brakes

• MK130.80.160 - 2027

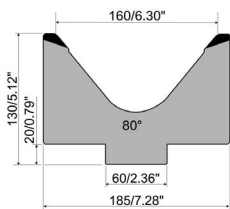

Length	PRICE
835 mm.	990,00 €
415 mm.	561,00 €
805 mm. Seg.	1.439,00 €

• S101.35.06

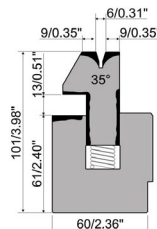

Length	PRICE
835 mm.	956,00 €
415 mm.	570,00 €

• S101.35.08

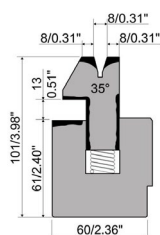

Length	PRICE
835 mm.	956,00 €
415 mm.	570,00 €

• S101.35.10

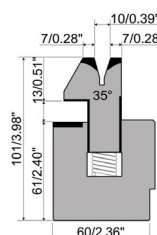

Length	PRICE
835 mm.	956,00 €
415 mm.	570,00 €

Broaching machine

Broaching machine BM25

The Hydraulic Broaching machine BM25 Nargesa, has been manufactured in a welded and mechanized steel monoblock. It is a machine to make slots and broaching operations in all kinds of parts. Sprockets, belts, gears, etc... It is also used as a press to straighten and unbolting oxidated parts, set baerings...

Reference	100-09-01-001
Motor power	2,2 KW / 3 HP
3-phased tensión	230 / 400 V
Hydraulic power	10 Tm
Working speed	24 mm/s
Return speed	54 mm/s
Pump Flow	7,5 L
Shank displacement	600 mm
Goosneck	300 mm
Maximum diameter of the piece	600 mm*
Bench dimensions	420x420 mm
Dimensions	750x1240x2400 mm
Weight	850 Kg
PRICE	13.028,00 €



* For different sizes, please ask the manufacturer

Accessories for Broaching machine



 Broaching time
0:30 min.

Keyway broaches 2mm	REF: 125-09-01-BR-00001
Tolerance	JS9 (-0,014 +0,009)
Model	A
Broach dimensions	3,175 x 127mm
Standard keys	2 x 2mm
Min./Max. Cutting length	5,159mm / 28,575mm
Required pressure	720lbs / 326,58Kg
Required shims/ Nr of passes	0 shims / 1 pass
Bushing diameter	6, 8, 10, 12 and 15mm
Bushing length	28,575mm
Weight	0,020 Kg. Approx.
PRICE	126,00 €

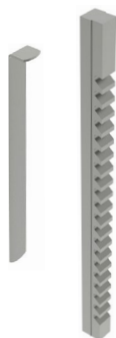

 Broaching time
0:45 min.

Keyway broaches 3mm	REF: 125-09-01-BR-00002
Tolerance	JS9 (-0,013 +0,009)
Model	A
Broach dimensions	3,175 x 127mm
Standard keys	3 x 3mm
Min./Max. Cutting length	5,159mm / 28,575mm
Required pressure	650lbs / 294,83Kg
Required shims/ Nr of passes	1 shim / 2 passes
Thickness	0,787mm
Bushing diameter	6, 8, 10, 12 y 15mm
Bushing length	28,575mm
Weight	0,020 Kg. Approx.
PRICE	126,00 €

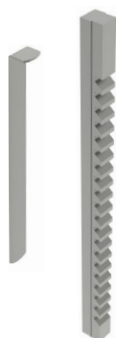



 Broaching time
1:00 min.

Keyway broaches 4mm	REF: 125-09-01-BR-00003
Tolerance	JS9 (-0,015 +0,01)
Model	B1
Broach dimensions	6,35 x 171,45mm
Standard keys	4 x 4mm
Min./Max. Cutting length	7,54mm / 42,862mm
Required pressure	1.140lbs / 517,09Kg
Required shims/ Nr of passes	1 shim / 2 passes
Thickness	0,965mm
Bushing diameter	12, 14, 15, 16, 17, 18 and 19mm
Bushing length	42,862mm
Weight	0,100 Kg. Approx.
PRICE	173,00 €



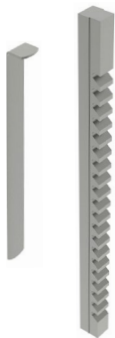

Accessories for Broaching machine

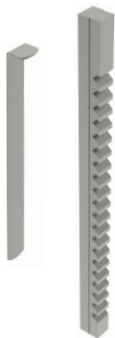

 Broaching time
1:00 min.

Keyway broaches 5mm	REF: 125-09-01-BR-00004
Tolerance	JS9 (-0,014 +0,008)
Model	B1
Broach dimensions	6,35 x 171,45mm
Standard keys	5 x 5mm
Min./Max. Cutting length	7,54mm / 42,862mm
Required pressure	1.860lbs / 843,68Kg
Required shims/ Nr of passes	1 shim / 2 passes
Thickness	1,27mm
Bushing diameter	12, 14, 15, 16, 17, 18 and 19mm
Bushing length	42,862mm
Weight	0,100 Kg. Approx.
PRICE	173,00 €



 Broaching time
1:20 min.

Keyway broaches 5mm	REF: 125-09-01-BR-00005
Tolerance	JS9 (-0,014 +0,008)
Model	C
Broach dimensions	9,52 x 298,45mm
Standard keys	5 x 5mm
Min./Max. Cutting length	9,921mm / 63,5mm
Required pressure	1.470lbs / 666,78Kg
Required shims/ Nr of passes	1 shim / 2 passes
Thickness	1,193mm
Bushing diameter	18, 19, 20, 22, 24, 25, 26, 28, 30, 32, 34, 35 and 36mm
Bushing length	63,5mm
Weight	0,350 Kg. Approx.
PRICE	191,00 €

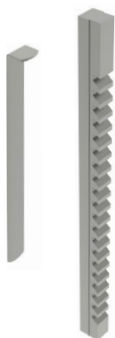

 Broaching time
1:20 min.

Keyway broaches 6mm	REF: 125-09-01-BR-00006
Tolerance	JS9 (-0,016 +0,009)
Model	C
Broach dimensions	9,52 x 298,45mm
Standard keys	6 x 6mm
Min./Max. Cutting length	9,921mm / 63,5mm
Required pressure	2.100lbs / 952,54Kg
Required shims/ Nr of passes	1 shim / 2 passes
Thickness	1,587mm
Bushing diameter	18, 19, 20, 22, 24, 25, 26, 28, 30, 32, 34, 35 and 36mm
Bushing length	63,5mm
Weight	0,350 Kg. Approx.
PRICE	191,00 €

Accessories for Broaching machine

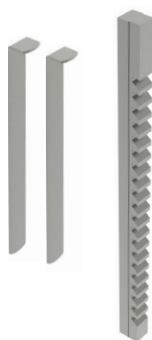

 Broaching time
2:30 min.

Keyway broaches 8mm	REF: 125-09-01-BR-00008
Tolerance	JS9 (-0,017 +0,013)
Model	C
Broach dimensions	9,52 x 298,45mm
Standard keys	8 x 7mm
Min./Max. Cutting length	9,921mm / 63,5mm
Required pressure	3.680lbs / 1.669,22Kg
Required shims/ Nr of passes	2 shims / 3 passees
Thickness	1,27mm
Bushing diameter	18, 19, 20, 22, 24, 25, 26, 28, 30, 32, 34, 35 and 36mm
Bushing length	63,5mm
Weight	0,350 Kg. Approx.
PRICE	191,00 €

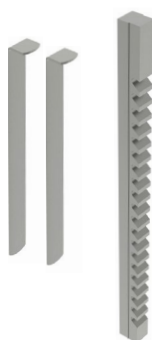

 Broaching time
2:30 min.

Keyway broaches 10mm	REF: 125-09-01-BR-00009
Tolerance	JS9 (-0,018 +0,012)
Model	D
Broach dimensions	14,28 x 352,42mm
Standard keys	10 x 8mm
Min./Max. Cutting length	25,4mm / 152,4mm
Required pressure	6.500lbs / 2.948,35Kg
Required shims/ Nr of passes	2 shims / 3 passes
Thickness	1,422mm
Bushing diameter	32, 34, 35, 36, 38, 40, 42, 44, 45, 46, 48, 50, 52, 54, 56mm
Bushing length	101,6 and 127mm
Weight	1 Kg. Approx.
PRICE	298,00 €

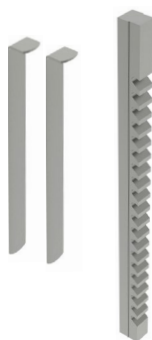

 Broaching time
2:30 min.

Keyway broaches 12mm	REF: 125-09-01-BR-00010
Tolerance	JS9 (-0,022 +0,014)
Model	D
Broach dimensions	14,28 x 352,42mm
Standard keys	12 x 8mm
Min./Max. Cutting length	25,4mm / 152,4mm
Required pressure	8.400lbs / 3.810,17Kg
Required shims/ Nr of passes	2 shims / 3 passes
Thickness	1,422mm
Bushing diameter	32, 34, 35, 36, 38, 40, 42, 44, 45, 46, 48, 50, 52, 54, 56mm
Bushing length	101,6 and 127mm
Weight	1 Kg. Approx.
PRICE	298,00 €

Accessories for Broaching machine

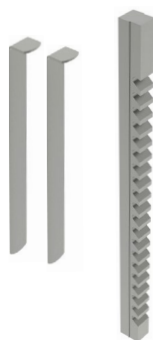

 Broaching time
2:30 min.

Keyway broaches 14mm	REF: 125-09-01-BR-00011
Tolerance	JS9 (-0,023 +0,013)
Model	D
Broach dimensions	14,28 x 352,42mm
Standard keys	14 x 9mm
Min./Max. Cutting length	25,4mm / 152,4mm
Required pressure	11.100lbs / 5.034,87Kg
Required shims/ Nr of passes	2 shims / 3 passes
Thickness	1,587mm
Bushing diameter	32, 34, 35, 36, 38, 40, 42, 44, 45, 46, 48, 50, 52, 54, 56mm
Bushing length	101,6 and 127mm
Weight	1 Kg. Approx.
PRICE	298,00 €

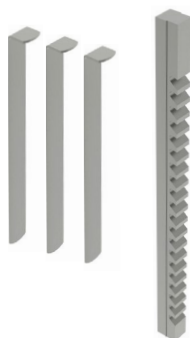

 Broaching time
3:40 min.

Keyway broaches 16mm	REF: 125-09-01-BR-00012
Tolerance	JS9 (-0,024 +0,012)
Model	E
Broach dimensions	19,05 x 393,7mm
Standard keys	16 x 10mm
Min./Max. Cutting length	25,4mm / 152,4mm
Required pressure	9.400lbs / 4.263,76Kg
Required shims/ Nr of passes	3 shims / 4 passes
Thickness	1,422mm
Bushing diameter	52, 54, 55, 56, 58, 60, 62, 63, 64, 65, 66, 68, 70, 72mm
Bushing length	127 and 152,4mm
Weight	1,5 Kg. Approx.
PRICE	446,00 €

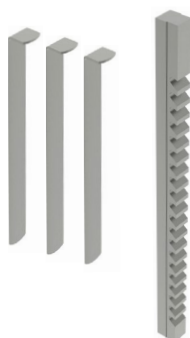

 Broaching time
3:40 min.

Keyway broaches 18mm	REF: 125-09-01-BR-00013
Tolerance	JS9 (-0,022 +0,013)
Model	E
Broach dimensions	19,05 x 393,7mm
Standard keys	18 x 11mm
Min./Max. Cutting length	25,4mm / 152,4mm
Required pressure	10.600lbs / 4.808,07Kg
Required shims/ Nr of passes	3 shims / 4 passes
Thickness	1,422mm
Bushing diameter	52, 54, 55, 56, 58, 60, 62, 63, 64, 65, 66, 68, 70, 72mm
Bushing length	127 and 152,4mm
Weight	1,5 Kg. Approx.
PRICE	446,00 €

Accessories for Broaching machine

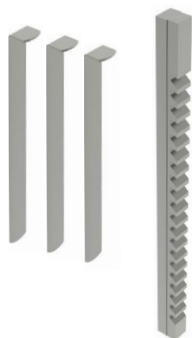

 Broaching time
4:20 min.

Keyway broaches 20mm		REF: 125-09-01-BR-00014
Tolerance		JS9 (-0,026 +0,015)
Model		F
Broach dimensions		25,40 x 514,35mm
Standard keys		20 x 12mm
Min./Max. Cutting length		25,4mm / 152,4mm
Required pressure		8.800lbs / 3.991,61Kg
Required shims/ Nr of passes		3 shims / 4 passes
Thickness		1,587mm
Bushing diameter	75, 80, 85, 90, 95, 100, 105, 110, 115 and 120mm	
Bushing length		152,4mm
Weight		3,5 Kg. Approx.
PRICE		803,00 €

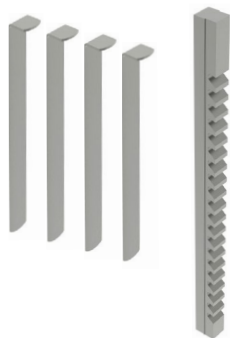

 Broaching time
5:00 min.

Keyway broaches 22mm		REF: 125-09-01-BR-00015
Tolerance		JS9 (-0,027 +0,014)
Model		F
Broach dimensions		25,40 x 514,35mm
Standard keys		22 x 14mm
Min./Max. Cutting length		25,4mm / 152,4mm
Required pressure		9.400lbs / 4.263,76Kg
Required shims/ Nr of passes		4 shims / 5 passes
Thickness		1,422mm
Bushing diameter	75, 80, 85, 90, 95, 100, 105, 110, 115 and 120mm	
Bushing length		152,4mm
Weight		3,5 Kg. Approx.
PRICE		803,00 €

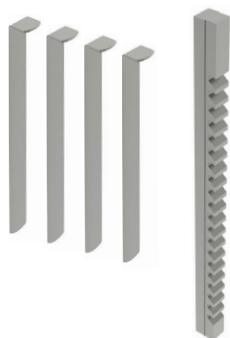

 Broaching time
5:00 min.

Keyway broaches 24mm		REF: 125-09-01-BR-00016
Tolerance		JS9 (-0,025 +0,015)
Model		F
Broach dimensions		25,40 x 514,35mm
Standard keys		24 x 14mm
Min./Max. Cutting length		25,4mm / 152,4mm
Required pressure		10.600lbs / 4.808,07Kg
Required shims/ Nr of passes		4 shims / 5 passes
Thickness		1,587mm
Bushing diameter	75, 80, 85, 90, 95, 100, 105, 110, 115 and 120mm	
Bushing length		152,4mm
Weight		3,5 Kg. Approx.
PRICE		803,00 €

Accessories for Broaching machine

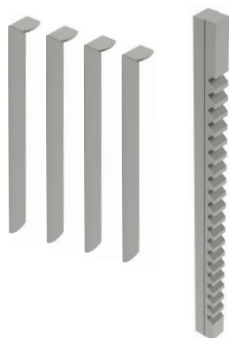

 Broaching time
5:00 min.

Keyway broaches 25mm		REF: 125-09-01-BR-00017
Tolerance		JS9 (-0,027 +0,013)
Model		F
Broach dimensions		25,40 x 514,35mm
Standard keys		25 x 14mm
Min./Max. Cutting length		25,4mm / 152,4mm
Required pressure		12.300lbs / 5.579,18Kg
Required shims/ Nr of passes		4 shims / 5 passes
Thickness		1,422mm
Bushing diameter	75, 80, 85, 90, 95, 100, 105, 110, 115 and 120mm	
Bushing length		152,4mm
Weight		3,5 Kg. Approx.
PRICE		803,00 €



 Broaching time
0:30 min.

Keyway broaches 1/16 inch		REF: 125-09-01-BRP-00001
Tolerance		JS9 (0,0625 · 0,0635)
Model		A
Broach dimensions		1/8 x 5 inches
Min./Max. Cutting length		13/64 inch / 1 1/8 inches
Required pressure		390lbs
Required shims/ Nr of passes		0 shims / 1 pass
Bushing diameter	1/4, 5/16, 3/8, 7/16 and 1/2 inch	
Bushing length		1 1/8 inches
Weight		0,020 Kg. Approx.
PRICE		126,00 €





 Broaching time
0:30 min.

Keyway broaches 3/32 inch		REF: 125-09-01-BRP-00002
Tolerance		JS9 (0,0938 · 0,0948)
Model		A
Broach dimensions		1/8 x 5 inches
Min./Max. Cutting length		13/64 inch / 1 1/8 inches
Required pressure		780lbs
Required shims/ Nr of passes		0 shims / 1 pass
Bushing diameter	1/4, 5/16, 3/8, 7/16 and 1/2 inches	
Bushing length		1 1/8 inches
Weight		0,020 Kg. Approx.
PRICE		126,00 €

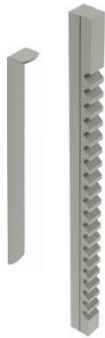

Accessories for Broaching machine



 Broaching time
0:45 min.

Keyway broaches 1/8 inch	REF: 125-09-01-BRP-00003
Tolerance	JS9 (0,1252 · 0,1262)
Model	A
Broach dimensions	1/8 x 5 inches
Min./Max. Cutting length	13/64 inch / 1 1/8 inches
Required pressure	650lbs
Required shims/ Nr of passes	1 shim / 2 passes
Thickness	0,0310 inches
Bushing diameter	1/4, 5/16, 3/8, 7/16 and 1/2 inches
Bushing length	1 1/8 inches
Weight	0,020 Kg. Approx.
PRICE	126,00 €



 Broaching time
0:40 min.

Keyway broaches 3/32 inch	REF: 125-09-01-BRP-00004
Tolerance	JS9 (0,0938 · 0,0948)
Model	B
Broach dimensions	3/16 x 6 3/4 inches
Min./Max. Cutting length	19/64 inch / 1 11/16 inches
Required pressure	930lbs
Required shims/ Nr of passes	0 shims / 1 pass
Bushing diameter	1/2, 9/16, 5/8, 11/16, 3/4, 13/16 and 7/8 inch
Bushing length	1 11/16 inches
Weight	0,100 Kg. Approx.
PRICE	173,00 €

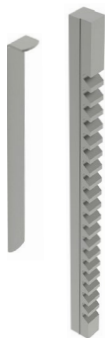



 Broaching time
1:00 min.

Keyway broaches 1/8 inch	REF: 125-09-01-BRP-00005
Tolerance	JS9 (0,1252 · 0,1262)
Model	B
Broach dimensions	3/16 x 6 3/4 inches
Min./Max. Cutting length	19/64 inch / 1 11/16 inches
Required pressure	720lbs
Required shims/ Nr of passes	1 shim / 2 passes
Thickness	0,0310 inches
Bushing diameter	1/2, 9/16, 5/8, 11/16, 3/4, 13/16 and 7/8 inches
Bushing length	1 11/16 inches
Weight	0,100 Kg. Approx.
PRICE	173,00 €



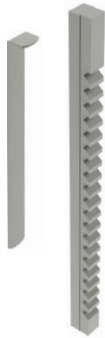

Accessories for Broaching machine

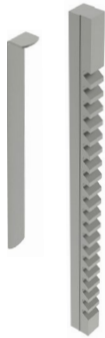

 Broaching time
1:00 min.

Keyway broaches 5/32 inch		REF: 125-09-01-BRP-00006
Tolerance	JS9 (0,1564 · 0,1574)	
Model	B	
Broach dimensions	3/16 x 6 3/4 inches	
Min./Max. Cutting length	19/64 inch / 1 11/16 inches	
Required pressure	1.320lbs	
Required shims/ Nr of passes	1 shim / 2 passes	
Thickness	0,0420 inches	
Bushing diameter	1/2, 9/16, 5/8, 11/16, 3/4, 13/16 and 7/8 inch	
Bushing length	1 11/16 inches	
Weight	0,100 Kg. Approx.	
PRICE	173,00 €	



 Broaching time
1:00 min.

Keyway broaches 3/16 inch		REF: 125-09-01-BRP-00007
Tolerance	JS9 (0,1877 · 0,1887)	
Model	B	
Broach dimensions	3/16 x 6 3/4 inches	
Min./Max. Cutting length	19/64 inch / 1 11/16 inches	
Required pressure	1.860lbs	
Required shims/ Nr of passes	1 shim / 2 passes	
Thickness	0,0500 inches	
Bushing diameter	1/2, 9/16, 5/8, 11/16, 3/4, 13/16 and 7/8 inches	
Bushing length	1 11/16 inches	
Weight	0,100 Kg. Approx.	
PRICE	173,00 €	

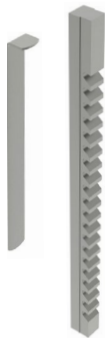



 Broaching time
1:20 min.

Keyway broaches 3/16 inch		REF: 125-09-01-BRP-00008
Tolerance	JS9 (0,1877 · 0,1887)	
Model	C	
Broach dimensions	3/8 x 11 3/4 inches	
Min./Max. Cutting length	25/64 inch / 2 1/2 inches	
Required pressure	1.540lbs	
Required shims/ Nr of passes	1 shim / 2 passes	
Thickness	0,0500 inches	
Bushing diameter	3/4, 13/16, 7/8, 15/16, 1, 1 1/16, 1 1/8, 1 3/16, 1 1/4, 1 5/16, 1 3/8, 1 7/16, 1 1/2 and 1 9/16 inches	
Bushing length	2 1/2 inches	
Weight	0,350 Kg. Approx.	
PRICE	191,00 €	



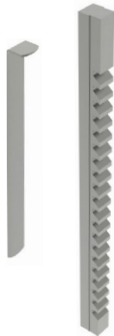

Accessories for Broaching machine

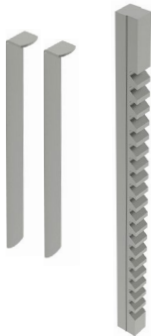

 Broaching time
1:20 min.

Keyway broaches 1/4 inch		REF: 125-09-01-BRP-00009
Tolerance	JS9 (0,2502 · 0,2512)	
Model	C	
Broach dimensions	3/8 x 11 3/4 inches	
Min./Max. Cutting length	25/64 inch / 2 1/2 inches	
Required pressure	2.520lbs	
Required shims/ Nr of passes	1 shim / 2 passes	
Thickness	0,0625 inches	
Bushing diameter	3/4, 13/16, 7/8, 15/16, 1, 1 1/16, 1 1/8, 1 3/16, 1 1/4, 1 5/16, 1 3/8, 1 7/16, 1 1/2 and 1 9/16 inches	
Bushing length	2 1/2 inches	
Weight	0,350 Kg. Approx.	
PRICE	191,00 €	



 Broaching time
2:30 min.

Keyway broaches 5/16 inch		REF: 125-09-01-BRP-00010
Tolerance	JS9 (0,3127 · 0,3137)	
Model	C	
Broach dimensions	3/8 x 11 3/4 inches	
Min./Max. Cutting length	25/64 inch / 2 1/2 inches	
Required pressure	3.960lbs	
Required shims/ Nr of passes	2 shims / 3 passes	
Thickness	0,0550 inches	
Bushing diameter	3/4, 13/16, 7/8, 15/16, 1, 1 1/16, 1 1/8, 1 3/16, 1 1/4, 1 5/16, 1 3/8, 1 7/16, 1 1/2 and 1 9/16 inches	
Bushing length	2 1/2 inches	
Weight	0,350 Kg. Approx.	
PRICE	191,00 €	

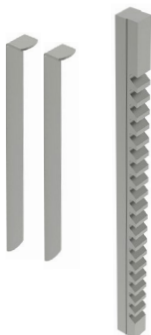



 Broaching time
2:30 min.

Keyway broaches 3/8 inch		REF: 125-09-01-BRP-00011
Tolerance	JS9 (0,3755 · 0,3765)	
Model	C	
Broach dimensions	3/8 x 11 3/4 inches	
Min./Max. Cutting length	25/64 inch / 2 1/2 inches	
Required pressure	4.340lbs	
Required shims/ Nr of passes	2 shims / 3 passes	
Thickness	0,0625 inches	
Bushing diameter	3/4, 13/16, 7/8, 15/16, 1, 1 1/16, 1 1/8, 1 3/16, 1 1/4, 1 5/16, 1 3/8, 1 7/16, 1 1/2 and 1 9/16 inches	
Bushing length	2 1/2 inches	
Weight	0,350 Kg. Approx.	
PRICE	191,00 €	



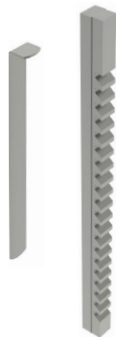

Accessories for Broaching machine

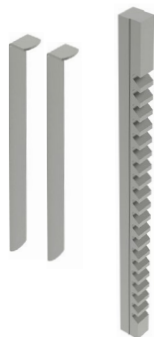

 Broaching time
2:30 min.

Keyway broaches 5/16 inch	REF: 125-09-01-BRP-00012
Tolerance	JS9 (0,3127 · 0,3137)
Model	D
Broach dimensions	9/16 x 13 7/8 inches
Min./Max. Cutting length	1 inch / 6 inches
Required pressure	8.000lbs
Required shims/ Nr of passes	2 shims / 3 passes
Thickness	0,0560 inches
Bushing diameter	1 7/16, 1 1/2, 1 9/16, 1 5/8, 1 11/16, 1 3/4, 1 13/16, 1 7/8, 1 15/16, 2, 2 1/16, 2 1/8, 2 3/16, 2 1/4, 2 5/16, 2 3/8, 2 7/16, 2 1/2, 2 9/16, 2 5/8, 2 11/16, 2 3/4, 2 13/16, 2 7/8, 2 15/16 and 3 inches
Bushing length	4 inches
Weight	1,00 Kg. Approx.
PRICE	298,00 €



 Broaching time
2:30 min.

Keyway broaches 3/8 inch	REF: 125-09-01-BRP-00013
Tolerance	JS9 (0,3755 · 0,3765)
Model	D
Broach dimensions	9/16 x 13 7/8 inches
Min./Max. Cutting length	1 inch / 6 inches
Required pressure	7.000lbs
Required shims/ Nr of passes	2 shims / 3 passes
Thickness	0,0625 inches
Bushing diameter	1 7/16, 1 1/2, 1 9/16, 1 5/8, 1 11/16, 1 3/4, 1 13/16, 1 7/8, 1 15/16, 2, 2 1/16, 2 1/8, 2 3/16, 2 1/4, 2 5/16, 2 3/8, 2 7/16, 2 1/2, 2 9/16, 2 5/8, 2 11/16, 2 3/4, 2 13/16, 2 7/8, 2 15/16 and 3 inches
Bushing length	4 inches
Weight	1,00 Kg. Approx.
PRICE	298,00 €



Accessories for Broaching machine

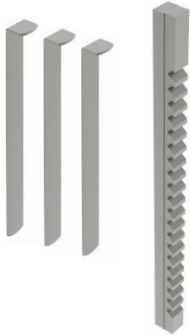

Keyway broaches 7/16 inch	REF: 125-09-01-BRP-00014
Tolerance	JS9 (0,4380 · 0,4390)
Model	D
Broach dimensions	9/16 x 13 7/8 inches
Min./Max. Cutting length	1 inch / 6 inches
Required pressure	9.400lbs
Required shims/ Nr of passes	3 shims / 4 passes
Thickness	0,0560 inches
Bushing diameter	1 7/16, 1 1/2, 1 9/16, 1 5/8, 1 11/16, 1 3/4, 1 13/16, 1 7/8, 1 15/16, 2, 2 1/16, 2 1/8, 2 3/16, 2 1/4, 2 5/16, 2 3/8, 2 7/16, 2 1/2, 2 9/16, 2 5/8, 2 11/16, 2 3/4, 2 13/16, 2 7/8, 2 15/16 and 3 inches
Bushing length	4 inches
Weight	1,00 Kg. Approx.
PRICE	298,00 €

 Broaching time
3:00 min.

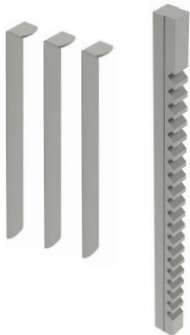

Keyway broaches 1/2 inch	REF: 125-09-01-BRP-00015
Tolerance	JS9 (0,5006 · 0,5016)
Model	D
Broach dimensions	9/16 x 13 7/8 inches
Min./Max. Cutting length	1 inch / 6 inches
Required pressure	9.800lbs
Required shims/ Nr of passes	3 shims / 4 passes
Thickness	0,0625 inches
Bushing diameter	1 7/16, 1 1/2, 1 9/16, 1 5/8, 1 11/16, 1 3/4, 1 13/16, 1 7/8, 1 15/16, 2, 2 1/16, 2 1/8, 2 3/16, 2 1/4, 2 5/16, 2 3/8, 2 7/16, 2 1/2, 2 9/16, 2 5/8, 2 11/16, 2 3/4, 2 13/16, 2 7/8, 2 15/16 and 3 inches
Bushing length	4 inches
Weight	1,00 Kg. Approx.
PRICE	298,00 €

 Broaching time
3:00 min.



Accessories for Broaching machine

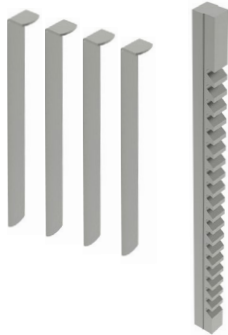

Broaching time
3:40 min.

Keyway broaches 9/16 inch	REF: 125-09-01-BRP-00016
Tolerance	JS9 (0,5631 · 0,5641)
Model	D
Broach dimensions	9/16 x 13 7/8 inches
Min./Max. Cutting length	1 inch / 6 inches
Required pressure	8.900lbs
Required shims/ Nr of passes	4 shims / 5 passes
Thickness	0,0560 inches
Bushing diameter	1 7/16, 1 1/2, 1 9/16, 1 5/8, 1 11/16, 1 3/4, 1 13/16, 1 7/8, 1 15/16, 2, 2 1/16, 2 1/8, 2 3/16, 2 1/4, 2 5/16, 2 3/8, 2 7/16, 2 1/2, 2 9/16, 2 5/8, 2 11/16, 2 3/4, 2 13/16, 2 7/8, 2 15/16 and 3 inches
Bushing length	6 inches
Weight	1,00 Kg. Approx.
PRICE	625,00 €

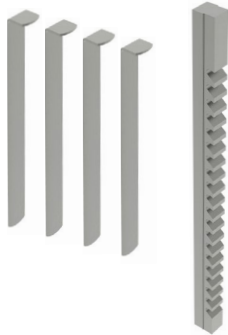



Broaching time
4:00 min.

Keyway broaches 5/8 inch	REF: 125-09-01-BRP-00017
Tolerance	JS9 (0,6260 · 0,6270)
Model	E
Broach dimensions	3/4 x 15 1/2 inches
Min./Max. Cutting length	1 inch / 6 inches
Required pressure	9.600lbs
Required shims/ Nr of passes	4 shims / 5 passes
Thickness	0,0625 inches
Bushing diameter	2 5/16, 2 3/8, 2 7/16, 2 1/2, 2 9/16, 2 5/8, 2 11/16, 2 3/4, 2 13/16, 2 7/8, 2 15/16, 3, 3 1/16, 3 1/8, 3 3/16, 3 1/4, 3 5/16, 3 3/8, 3 7/16, 3 1/2, 3 9/16, 3 5/8, 3 11/16, 3 3/4, 3 13/16, 3 7/8, 3 15/16 and 4 inches
Bushing length	6 inches
Weight	1,500 Kg. Approx.
PRICE	446,00 €



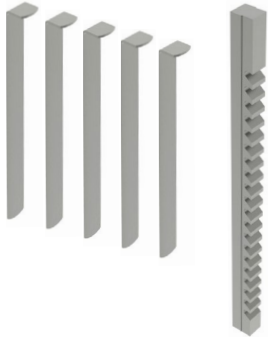

Accessories for Broaching machine

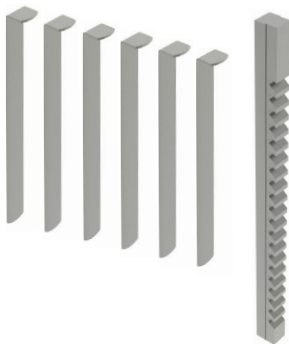

 Broaching time
5:00 min.

Keyway broaches 3/4 inch	REF: 125-09-01-BRP-00018
Tolerance	JS9 (0,7515 · 0,7525)
Model	E
Broach dimensions	3/4 x 15 1/2 inches
Min./Max. Cutting length	1 inch / 6 inches
Required pressure	11.900lbs
Required shims/ Nr of passes	5 shims / 6 passes
Thickness	0,0625 inches
Bushing diameter	2 5/16, 2 3/8, 2 7/16, 2 1/2, 2 9/16, 2 5/8, 2 11/16, 2 3/4, 2 13/16, 2 7/8, 2 15/16, 3, 3 1/16, 3 1/8, 3 3/16, 3 1/4, 3 5/16, 3 3/8, 3 7/16, 3 1/2, 3 9/16, 3 5/8, 3 11/16, 3 3/4, 3 13/16, 3 7/8, 3 15/16 and 4 inches
Bushing length	6 inches
Weight	1,500 Kg. Approx.
PRICE	446,00 €



 Broaching time
6:00 min.

Keyway broaches 7/8 inch	REF: 125-09-01-BRP-00019
Tolerance	JS9 (0,8765 · 0,8775)
Model	F
Broach dimensions	1 x 20 1/4 inches
Min./Max. Cutting length	1 inch / 6 inches
Required pressure	9.800lbs
Required shims/ Nr of passes	6 shims / 7 passes
Thickness	0,0625 inches
Bushing diameter	3 1/16, 3 1/8, 3 3/16, 3 1/4, 3 5/16, 3 3/8, 3 7/16, 3 1/2, 3 9/16, 3 5/8, 3 11/16, 3 3/4, 3 13/16, 3 7/8, 3 15/16, 4, 4 1/16, 4 1/8, 4 3/16, 4 1/4, 4 5/16, 4 3/8, 4 7/16, 4 1/2, 7 9/16, 4 5/8, 4 11/16, 4 3/4, 4 13/16, 4 7/8, 4 15/16 and 5 inches
Bushing length	6 inches
Weight	3,500 Kg. Approx.
PRICE	803,00 €



Accessories for Broaching machine

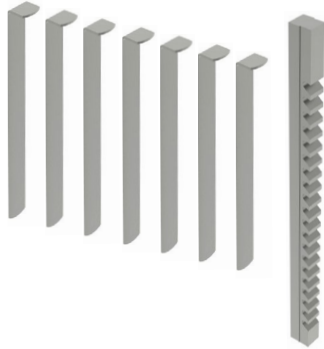

Keyway broaches 1 inch	REF: 125-09-01-BRP-00020
Tolerance	JS9 (1,0015 · 1,0025)
Model	F
Broach dimensions	1 x 20 1/4 inches
Min./Max. Cutting length	1 inch / 6 inches
Required pressure	11.100lbs
Required shims/ Nr of passes	7 shims / 8 passes
Thickness	0,0625 inches
Bushing diameter	3 1/16, 3 1/8, 3 3/16, 3 1/4, 3 5/16, 3 3/8, 3 7/16, 3 1/2, 3 9/16, 3 5/8, 3 11/16, 3 3/4, 3 13/16, 3 7/8, 3 15/16, 4, 4 1/16, 4 1/8, 4 3/16, 4 1/4, 4 5/16, 4 3/8, 4 7/16, 4 1/2, 7 9/16, 4 5/8, 4 11/16, 4 3/4, 4 13/16, 4 7/8, 4 15/16 and 5 inches
Bushing length	6 inches
Weight	3,500 Kg. Approx.
PRICE	803,00 €

 Broaching time
8:00 min.

Accessories for Broaching machine

Bushings



F114 steel guide bushes in H8 diameter tolerance to optimize the perfect finish of the part.

For other dimensions, request the manufacturer.

Reference	Model	Diameter	Length	Tolerance	Broaches	PRICE
125-09-01-CBR-00002	A	10 mm	32 mm	J9	2 - 3 mm	90,00 €
125-09-01-CBR-00004	B	12 mm	46 mm	J9	4 - 5C mm	90,00 €
125-09-01-CBR-00005	B	14 mm	46 mm	J9	4 - 5C mm	90,00 €
125-09-01-CBR-00006	B	16 mm	46 mm	J9	4 - 5C mm	90,00 €
125-09-01-CBR-00007	B	17 mm	46 mm	J9	4 - 5C mm	90,00 €
125-09-01-CBR-00008	C	18 mm	65 mm	J9	5 - 6 - 8 mm	90,00 €
125-09-01-CBR-00009	C	19 mm	65 mm	J9	5 - 6 - 8 mm	90,00 €
125-09-01-CBR-00010	C	20 mm	65 mm	J9	5 - 6 - 8 mm	90,00 €
125-09-01-CBR-00011	C	22 mm	65 mm	J9	5 - 6 - 8 mm	90,00 €
125-09-01-CBR-00012	C	24 mm	65 mm	J9	5 - 6 - 8 mm	90,00 €
125-09-01-CBR-00013	C	25 mm	65 mm	J9	5 - 6 - 8 mm	90,00 €
125-09-01-CBR-00014	C	28 mm	65 mm	J9	5 - 6 - 8 mm	90,00 €
125-09-01-CBR-00015	C	30 mm	65 mm	J9	5 - 6 - 8 mm	90,00 €
125-09-01-CBR-00016	D	32 mm	102 mm	J9	10 - 12 - 14 mm	102,00 €
125-09-01-CBR-00017	D	35 mm	102 mm	J9	10 - 12 - 14 mm	102,00 €
125-09-01-CBR-00018	D	38 mm	102 mm	J9	10 - 12 - 14 mm	102,00 €
125-09-01-CBR-00020	D	40 mm	102 mm	J9	10 - 12 - 14 mm	102,00 €
125-09-01-CBR-00021	D	42 mm	102 mm	J9	10 - 12 - 14 mm	102,00 €
125-09-01-CBR-00022	D	45 mm	127 mm	J9	10 - 12 - 14 mm	102,00 €
125-09-01-CBR-00023	D	48 mm	127 mm	J9	10 - 12 - 14 mm	102,00 €
125-09-01-CBR-00024	D	50 mm	127 mm	J9	10 - 12 - 14 mm	102,00 €
125-09-01-CBR-00025	E	55 mm	127 mm	J9	16 - 18 mm	109,00 €
125-09-01-CBR-00026	E	60 mm	154 mm	J9	16 - 18 mm	109,00 €
125-09-01-CBR-00027	E	65 mm	154 mm	J9	16 - 18 mm	109,00 €
125-09-01-CBR-00028	F	70 mm	154 mm	J9	20 - 22 - 24 - 25 mm	209,00 €
125-09-01-CBR-00029	F	75 mm	154 mm	J9	20 - 22 - 24 - 25 mm	209,00 €
125-09-01-CBR-00030	F	80 mm	154 mm	J9	20 - 22 - 24 - 25 mm	260,00 €
125-09-01-CBR-00031	F	85 mm	154 mm	J9	20 - 22 - 24 - 25 mm	260,00 €
125-09-01-CBR-00032	F	90 mm	154 mm	J9	20 - 22 - 24 - 25 mm	312,00 €
125-09-01-CBR-00033	F	95 mm	154 mm	J9	20 - 22 - 24 - 25 mm	312,00 €

Power hammer

Power hammer PH50

In collaboration with some of the best blacksmiths in Spain, France and the United States, the Prada Nargesa engineers have designed a power hammer with all sorts of new advances in comparison to the other drop hammers on the market up until now. **Easier to manage, more precise, safer, quieter and with no need for any civil engineering work for installation in addition to many other features, it's the best choice available.**

Reference	100-14-03-001
Engine power	4 kW / 5,5 CV
Nominal dropping weight	50 kg / 110 lb
Strokes per minute	240
Ram range	180 mm / 7"
Operating range	220 mm / 9"
Max. round working capacity	70 mm / 2,75"
Max. square working capacity	60x60/ 2,36"
Dimensions	808x1289x1768mm
Weight	1002 Kg
PRICE	10.101,00 €



Before purchasing a power hammer, a few basic details are needed before making a final decision:

BUILT-IN COMPRESSOR: The PH50 power hammer has a built-in compressor. This means, unlike with other brands, no external compressor is needed. A 50 kg or 110 lb power hammer without a built-in compressor would need a 5 HP external compressor.

NO NEED FOR SPECIFIC CIVIL ENGINEERING FOR INSTALLATION: Only 4 holes are needed in a concrete floor to insert the 4 chemical bolts that come with the machine when installing the PH50 power hammer.

WELDED STEEL FRAME: The machine frame is not casted; it's made of welded and die-cut steel. This reduces the possibility of cracking, as occurs with cast power hammers.

MAXIMUM CONTROLLED DROP PRECISION: We achieved maximum precision with the ability to even close a box of matches or position an egg and collide with it without breaking it.

LAPPED CYLINDERS DESIGNED WITH LOW-FRICTION TECHNOLOGY: The friction between the sleeve and piston is normally mechanical and through steel rings. This causes a risk of seizing up over time.

INTAKE AND EXHAUST MUFFLERS: Two mufflers, on the intake and exhaust, reduce the noise to xx dB.

AUTOMATIC LUBRICATION SYSTEM: The lubrication system on the PH50 power hammer features a completely transparent tank next to the power switch to monitor the level of oil in the container without having to use uncomfortable inspection peepholes.

DOUBLE MECHANICAL STOP PROTECTION: The piston on the front and pedal become completely mechanically blocked in an ideal position to easily and safely change the molds.

COLLECTING AND FILTERING OIL FROM THE AIR: The Nargesa PH50 drop hammer has a tank that collects this mix and separates the two components.

SAFET & CE MARKING: All of our machines are compliant with EC industrial machinery manufacturing standards.

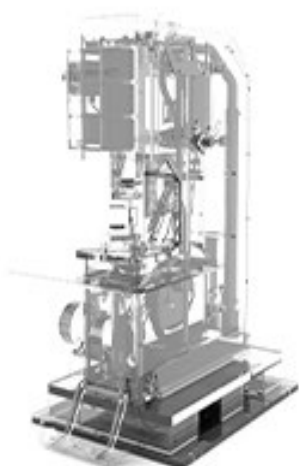

Accessories for Power hammer

Standard flat mold for Power Hammer PH50

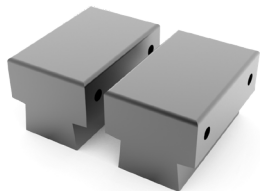

REF: 140-14-04-00001

> All our Power-hammers are equipped with an upper standard flat tooling and lower one.

> This tooling is the most versatile one and it's bond to the operatives skilfulness.

> Molds manufactured and tempered in 1.2344 steel / AFNOR: Z40CDV5 / DIN: X40CrMoV5-1 / UNE: F5318 / AISI: SAE H13 / SKD61 / 45Cr5MoSiV1 to withstand major impacts and high temperatures.

Standard tool

N° of pieces	Dimensions	PRICE
2	120x78mm	778,00 €

Support braces/ adaptors for Power Hammer PH50



REF: 140-14-04-00002

> We supply two sets of Support braces along with the power hammer PH50.

These adaptors enable us to weld or fasten with bolts to them several kinds of elements, such as round and square solid bars, flat bars, rods etc... in order to manufacture our own tools.

> Tools made of Steel F111.

Standard tool

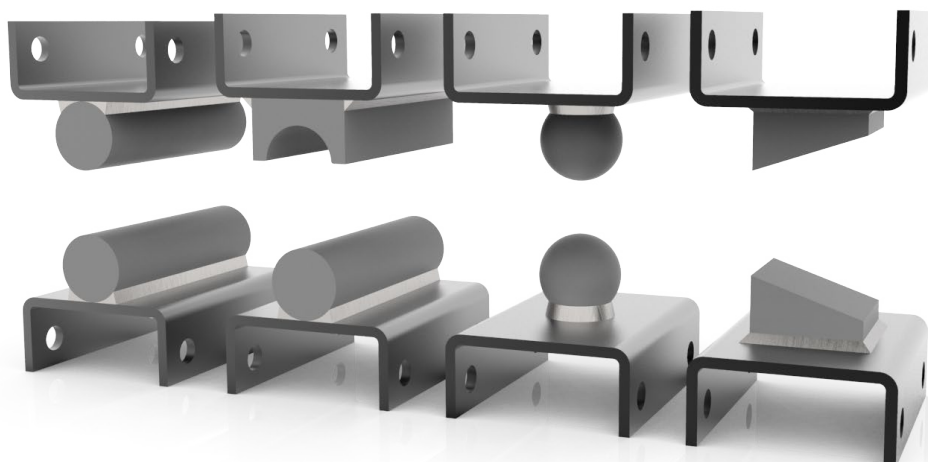
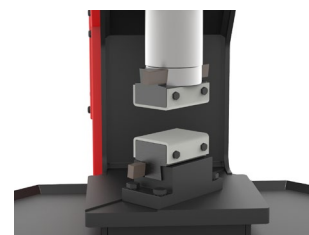

N° of pieces	Dimensions	PRICE
4	120x89mm	84,00 €

Accessories for Power hammer

Tool for Power Hammer 04

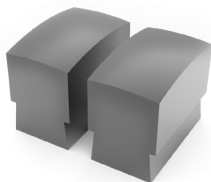

REF: 140-14-01-00004

> Molds manufactured and tempered in 1.2344 steel /
AFNOR: Z40CDV5 / DIN: X40CrMoV5-1 / UNE: F5318 /
AISI: SAE H13 / SKD61 / 45Cr5MoSiV1 to withstand major
impacts and high temperatures.

N° of pieces	Dimensions	PRICE
2	100x60mm	1.062,00 €

Tool for Power Hammer 06

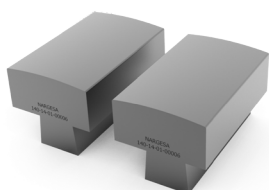

REF: 140-14-01-00006

> Molds manufactured and tempered in 1.2344 steel /
AFNOR: Z40CDV5 / DIN: X40CrMoV5-1 / UNE: F5318 /
AISI: SAE H13 / SKD61 / 45Cr5MoSiV1 to withstand major
impacts and high temperatures.

N° of pieces	Dimensions	PRICE
2	120x60mm	1.062,00 €

Tool for Power Hammer 07

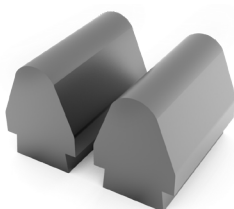

REF: 140-14-01-00007

> Molds manufactured and tempered in 1.2344 steel /
AFNOR: Z40CDV5 / DIN: X40CrMoV5-1 / UNE: F5318 /
AISI: SAE H13 / SKD61 / 45Cr5MoSiV1 to withstand major
impacts and high temperatures.

N° of pieces	Dimensions	PRICE
2	120x60mm	1.338,00 €

Tool for Power Hammer 08

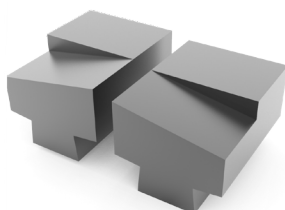

REF: 140-14-01-00008

> Molds manufactured and tempered in 1.2344 steel /
AFNOR: Z40CDV5 / DIN: X40CrMoV5-1 / UNE: F5318 /
AISI: SAE H13 / SKD61 / 45Cr5MoSiV1 to withstand major
impacts and high temperatures.

N° of pieces	Dimensions	PRICE
2	130x100mm	1.338,00 €

Accessories for Power hammer

Tool for Power Hammer 09



REF: 140-14-01-00009

> Molds manufactured and tempered in 1.2344 steel /
AFNOR: Z40CDV5 / DIN: X40CrMoV5-1 / UNE: F5318 /
AISI: SAE H13 / SKD61 / 45Cr5MoSiV1 to withstand major
impacts and high temperatures.

N° of pieces	Dimensions	PRICE
2	120x60mm	1.291,00 €

Tool for Power Hammer 10



REF: 140-14-01-00010

> Molds manufactured and tempered in 1.2344 steel /
AFNOR: Z40CDV5 / DIN: X40CrMoV5-1 / UNE: F5318 /
AISI: SAE H13 / SKD61 / 45Cr5MoSiV1 to withstand major
impacts and high temperatures.

N° of pieces	Dimensions	PRICE
2	120x60mm	1.405,00 €

Tool for Power Hammer 13

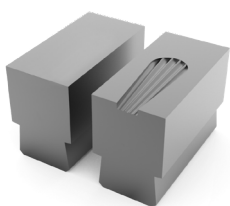

REF: 140-14-01-00013

> Molds manufactured and tempered in 1.2344 steel /
AFNOR: Z40CDV5 / DIN: X40CrMoV5-1 / UNE: F5318 /
AISI: SAE H13 / SKD61 / 45Cr5MoSiV1 to withstand major
impacts and high temperatures.



N° of pieces	Dimensions	Capacity	PRECIO
2	120x60mm	Ø 12mm ∇ 12mm	1.254,00 €

Tool for Power Hammer 18

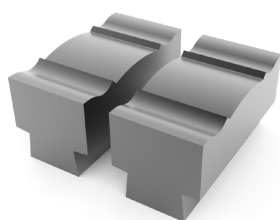

REF: 140-14-01-00018

> Molds manufactured and tempered in 1.2344 steel /
AFNOR: Z40CDV5 / DIN: X40CrMoV5-1 / UNE: F5318 /
AISI: SAE H13 / SKD61 / 45Cr5MoSiV1 to withstand major
impacts and high temperatures.



N° of pieces	Dimensions	PRICE
2	160x80mm	1.550,00 €

Accessories for Power hammer

Tool for Power Hammer 19

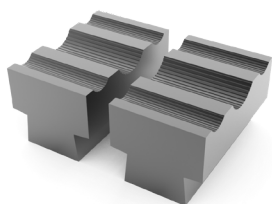

REF: 140-14-01-00019

> Molds manufactured and tempered in 1.2344 steel /
AFNOR: Z40CDV5 / DIN: X40CrMoV5-1 / UNE: F5318 /
AISI: SAE H13 / SKD61 / 45Cr5MoSiV1 to withstand major
impacts and high temperatures.



N° of pieces	Dimensions	Capacity	PRICE
2	130x80mm	Ø12mm - 16mm - 20mm	1.586,00 €

Tool for Power Hammer 20



REF: 140-14-01-00020

> Molds manufactured and tempered in 1.2344 steel /
AFNOR: Z40CDV5 / DIN: X40CrMoV5-1 / UNE: F5318 /
AISI: SAE H13 / SKD61 / 45Cr5MoSiV1 to withstand major
impacts and high temperatures.



N° of pieces	Dimensions	Capacity	PRICE
2	120x100mm	12x12mm	1.405,00 €

Tool for Power Hammer 21

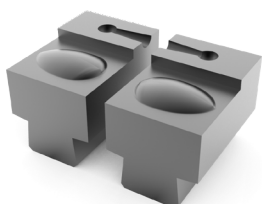

REF: 140-14-01-00021

> Molds manufactured and tempered in 1.2344 steel /
AFNOR: Z40CDV5 / DIN: X40CrMoV5-1 / UNE: F5318 /
AISI: SAE H13 / SKD61 / 45Cr5MoSiV1 to withstand major
impacts and high temperatures.



N° of pieces	Dimensions	Capacity	PRICE
2	120x70mm	Ø 14mm	1.405,00 €

Tool for Power Hammer 22



REF: 140-14-01-00022

> Molds manufactured and tempered in 1.2344 steel /
AFNOR: Z40CDV5 / DIN: X40CrMoV5-1 / UNE: F5318 /
AISI: SAE H13 / SKD61 / 45Cr5MoSiV1 to withstand major
impacts and high temperatures.



N° of pieces	Dimensions	PRICE
2	135x60mm	1.182,00 €

Accessories for Power hammer

Tool for Power Hammer 23



REF: 140-14-01-00023

> Molds manufactured and tempered in 1.2344 steel /
AFNOR: Z40CDV5 / DIN: X40CrMoV5-1 / UNE: F5318 /
AISI: SAE H13 / SKD61 / 45Cr5MoSiV1 to withstand major
impacts and high temperatures.



N° of pieces	Dimensions	Capacity	PRICE
2	70x60mm	Ø 16mm	1.197,00 €

Tool for Power Hammer 24

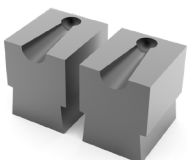

REF: 140-14-01-00024

> Molds manufactured and tempered in 1.2344 steel /
AFNOR: Z40CDV5 / DIN: X40CrMoV5-1 / UNE: F5318 /
AISI: SAE H13 / SKD61 / 45Cr5MoSiV1 to withstand major
impacts and high temperatures.



N° of pieces	Dimensions	Capacity	PRICE
2	70x60mm	Ø 16mm ∇ 16mm	1.197,00 €

Special dies

- > Special customized tools
- > Molds manufactured and tempered in 1.2344 steel / AFNOR:
Z40CDV5 / DIN: X40CrMoV5-1 / UNE: F5318 / AISI: SAE H13 / SKD61 /
45Cr5MoSiV1 to withstand major impacts and high temperatures.

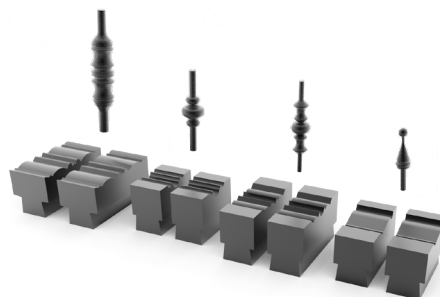

Oil SIL CN-20



REF: 060-BA-00030

- > Special refined mineral oil for pneumatic circuits.
- > Container: 5L

PRICE: 38,00 €

Hot Forging Press

Hot Forging Press PV21

New Generation of PV21 Hot Forging Presses, easier to operate, more precise, quieter, safer, and with many other features

In collaboration with some of the best blacksmiths in Spain, France and the United States, the Prada Nargesa engineers have designed a forging press with all sorts of features. Easier to handle, more accurate, more silent, safer and with many more features that make it the best choice among all the presses currently available on the market as more than 90% of the others unfortunately do not even comply with EC regulations.

Reference	100-18-01-001
Motor power	2,2 Kw / 3 CV a 1460 r.p.m
Voltage	230/400V Trifásica 230V Monofásica
Intensity	9/5 A
Pump	7,5 l./m
Tank	27 litros
Double rotor	21 Tn
Hydraulic pressure	200 Kg/cm2 (20 MPa)
Structure material	Chapa
Dimensions	790 x 800 x 1940 mm
Total weight	500 Kg
PRICE	8.900,00 €



Accessories for Hot Forging Press

20 bending mold



REF: 140-18-01-00020

>Molds with two work areas to stretch and flatten material. Highly versatile.

> Molds manufactured and tempered in 1.2344 steel / AFNOR: Z40CDV5 / DIN: X40CrMoV5-1 / UNE: F5318 / AISI: SAE H13 / SKD61 / 45Cr5MoSiV1 to withstand major effort and high temperatures. This material maintains its mechanical properties at high temperatures.

Standard tooling



Mold dimensions	Total weight	PRICE
130x80x67mm	6,60kg	793,00 €

PV21 single base



REF: 140-18-01-00001

>Two bases to be able to weld or screw together any mold manufactured by the customer, as per the work needs.

Bases made of F-111 steel.

Standard tooling

Mold dimensions	Total weight	PRICE
230x135x15mm	6,10kg	74,00 €

PV21 base with hole in the middle



REF: 140-18-01-00004

>Two bases to be able to weld or screw together any mold manufactured by the customer, as per the work needs.

These bases were designed for hot punching.

Bases made of F-111 steel.

Standard tooling

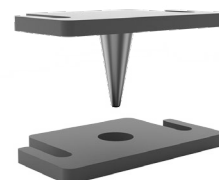

Mold dimensions	Total weight	PRICE
230x135x15mm	6,00kg	94,00 €

Accessories for Hot Forging Press

PV21 front assembly base

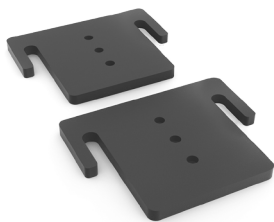

REF: 140-18-01-00005

> Two bases to be able to screw any of the molds we manufacture together, perpendicular to their original position.

Bases made of F-111 steel.

Standard tooling

Mold dimensions	Total weight	PRICE
230x185x15mm	7,60kg	130,00 €

PV21 double base

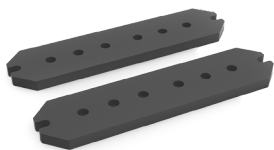

REF: 140-18-01-00006

> Two bases to be able to screw any of the molds we manufacture together, one next to the other.

Bases made of F-111 steel.

Standard tooling

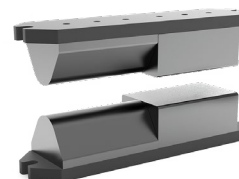

Mold dimensions	Total weight	PRICE
325x80x15mm	5,60kg	105,00 €

Accessories for Hot Forging Press

21 bending mold



REF: 140-18-01-00021

> Pyramid-shaped molds to form the material and stretch it faster.

> Molds manufactured and tempered in 1.2344 steel / AFNOR: Z40CDV5 / DIN: X40CrMoV5-1 / UNE: F5318 / AISI: SAE H13 / SKD61 / 45Cr5MoSiV1 to withstand major effort and high temperatures. This material maintains its mechanical properties at high temperatures.

Optional tooling



Mold dimensions	Total weight	PRICE
130x80x67mm	6,10kg	970,00 €

22 bending mold

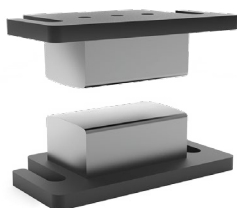

REF: 140-18-01-00022

> Molds with a rounded surface to stretch material without excessive deformation.

> Molds manufactured and tempered in 1.2344 steel / AFNOR: Z40CDV5 / DIN: X40CrMoV5-1 / UNE: F5318 / AISI: SAE H13 / SKD61 / 45Cr5MoSiV1 to withstand major effort and high temperatures. This material maintains its mechanical properties at high temperatures.

Optional tooling



Mold dimensions	Total weight	PRICE
130x80x67mm	7,20kg	970,00 €

23 bending mold

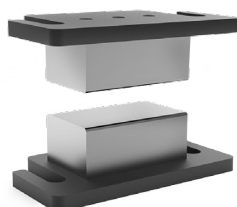

REF: 140-18-01-00023

> Flat molds to flatten material with small radius edges, to create steps.

> Molds manufactured and tempered in 1.2344 steel / AFNOR: Z40CDV5 / DIN: X40CrMoV5-1 / UNE: F5318 / AISI: SAE H13 / SKD61 / 45Cr5MoSiV1 to withstand major effort and high temperatures. This material maintains its mechanical properties at high temperatures.

Optional tooling



Mold dimensions	Total weight	PRICE
130x80x67mm	7,30kg	793,00 €

Accessories for Hot Forging Press

24 bending mold

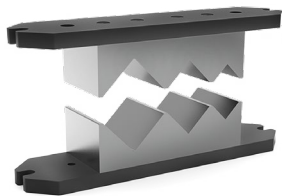

REF: 140-18-01-00024

> Dies with three V-shaped slots (2", 1" 1/2 and 1") for pressing steel. Specially designed to avoid changing tools by unifying three sizes in the same tool. Ideal for manufacturing parts with Damascus steel.

> Molds manufactured and tempered in 1.2344 steel / AFNOR: Z40CDV5 / DIN: X40CrMoV5-1 / UNE: F5318 / AISI: SAE H13 / SKD61 / 45Cr5MoSiV1 to withstand major effort and high temperatures. This material maintains its mechanical properties at high temperatures.

Optional tooling



Mold dimensions	Total weight	PRICE
325x80x67mm	14,5 kg	1.244,00 €

Forge furnaces

Forge furnace H1

The new propane forging furnace H1 NARGESA, has been designed to heat up steel in a more efficient and safe way, respecting environment.

More efficient: up to a 75% less gas, achieving higher temperature that any furnace of its range.

Safer: new safety systems for the operator, according to the regulation RD919/2006.

100% Respectful with environment: lower than 0.002€ CO. Inside cover with vermiculite 100% natural and eco-friendly.

Reference	100-04-03-001
Dimensions of combustion chamber	236x140x100 mm
Type of fuel	Propane gas (GLP)
Gas intake as 1 per bar	0,35 Kg/h
Adjustable working pressure	0,1 - 1,5 bar
Power (Hi)	4 kW
Maximum temperature	1300 °C
Nr of burners	1
External dimensions	310x450x370 mm
Weight	27 Kg
PRICE	1.156,00 €



Forge furnace H2

The new propane forging furnace H2 NARGESA, has been designed to heat up steel in a more efficient and safe way, respecting environment.

More efficient: up to a 75% less gas, achieving higher temperature that any furnace of its range.

Safer: new safety systems for the operator, according to the regulation RD919/2006.

100% Respectful with environment: lower than 0.002€ CO. Inside cover with vermiculite 100% natural and eco-friendly.

Reference	100-04-01-001
Dimensions of combustion chamber	324x240x100 mm
Type of fuel	Propane gas (GLP)
Gas intake as 1 per bar	0,7 Kg/h
Adjustable working pressure	0,1 - 1,5 bar
Power (Hi)	8 kW
Maximum temperature	1300 °C
Nr of burners	2
External dimensions	500x440x370 mm
Weight	40 Kg
PRICE	1.607,00 €

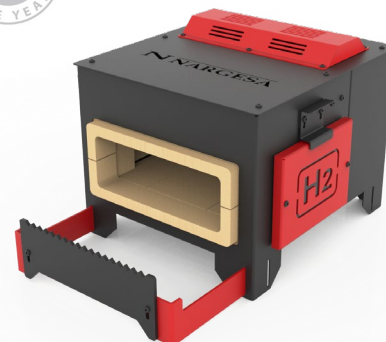

Forge furnaces

Forge furnace H3

The new propane forging furnace H3 NARGESA, has been designed to heat up steel in a more efficient and safe way, respecting environment.

More efficient: up to a 75% less gas, achieving higher temperature that any furnace of its range.

Safer: new safety systems for the operator, according to the regulation RD919/2006.

100% Respectful with environment: lower than 0.002€ CO. Inside cover with vermiculite 100% natural and eco-friendly.

Reference	100-04-04-001
Dimensions of combustion chamber	464x240x100 mm
Type of fuel	Propane gas (GLP)
Gas intake as 1 per bar	1 Kg/h
Adjustable working pressure	0,1 - 1,5 bar
Power (Hi)	12 kW
Maximum temperature	1300 °C
Nr of burners	3
External dimensions	510x580x370 mm
Weight	53 Kg
PRICE	2.331,00 €

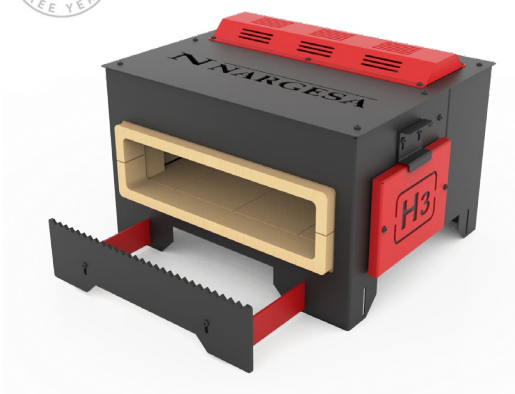

End Forging Machines

End forgin machine PC16

The End Hot Wrought Machine Nargesa PC16, eases up the rolling job of hot steel. It rolls up the snail forged shaped end. This decorations are commonly used as extremes in scrolls and decorative parts. Gates, windows, fencing, metal furniture...

Reference	100-15-01-001
Engine power	2,2 KW / 3HP
Three phased tensión	230/400 V
Maximum capacity in round	20 mm
Maximum capacity in square	20 mm
Maximum capacity in flat bar	50x10 mm
Working speed	45 mm/s
Return speed	70 mm/s
Cycle time	10 s
Pieces per minute	4 pieces
Dimensions	640x1300x1110 mm
Weight	336 Kg
PRICE	6.911,00 €



Wrought iron machine NF70

The Wrought iron Machine Nargesa NF70 smashes and molds irons up to obtaining the desired shape depending on the mold design. It forges arrow ends or lances of different kinds; flat, pyramidal, etc. It also makes baluster extremes to accomplish nice ornamental parts by changing the die. It forges and smashes balusters in the middle to make different designs.

Reference	100-12-02-001
Engine power	5,5 KW / 7HP
Three phased tensión	230/400 V
Maximum capacity in round	20 mm
Maximum capacity in square	20 mm
Maximum capacity in flat bar	40x10 mm
Rotation speed	20 rpm a 50Hz
Dimensions	620x1040x1250 mm
Weight	493 Kg
PRICE	11.138,00 €



Accessories for End Forging Machine NF70

Set of special rollers

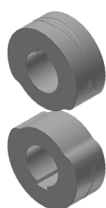

Reference: 140-12-02-00001

We design and manufacture all kind of special rollers under request.

Set of trilobular rollers

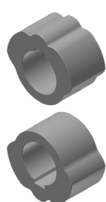

Reference: 140-12-02-00003

Set of trilobular rollers to emboss decoration in the middle of a baluster.

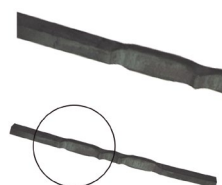

Units per set	Maximum capacity	Maximum capacity	Weight	PRICE
2	Round and square 20mm	Rectangular 50x10mm	4,2 Kg./uni	1.016,00 €

Set of triple middle marking rollers



Reference: 140-12-02-00004

Set of excentric rollers to emboss the middle of ba-lusters. Triple design, flat, striped and discontinuous in the same roller.

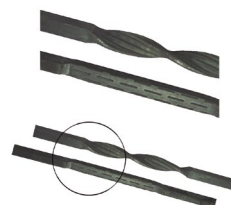

Units per set	Maximum capacity	Maximum capacity	Weight	PRICE
2	Round and square 20mm	Rectangular 50x10mm	8,5 Kg./uni	1.016,00 €

Set of fishtail roller

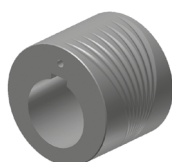

Reference: 140-12-02-00005

Two-grooved roller, one for big diameters and the other one for smaller diameters.



Units per set	Maximum capacity	Maximum capacity	Weight	PRICE
1	Round and square 20mm	Rectangular 50x10mm	7,7 Kg./uni	1.016,00 €

Iron embossing machine

Iron embossing machine NOA60

The purpose of NOA60 Nargesa is to conform and emboss designs on cold flat bars, square bars and square pipes. The shape and the design of the job will depend on the rollers used.

Reference	100-11-01-002
Engine power	5,5 KW / 7,5 HP
Three phased tensión	230 / 400 V
Power consumption	21/12 A
Nominal working speed	20 r.p.m. a 50 Hz
Max. on square pipe	60 mm o 2" 1/2
Max. on square bar	20 mm o 3/4"
Max. on handrail or flat bar	60x10 mm o 2"x3/8
Dimensions	780x1230x1400 mm
Weight	746 Kg
PRICE	20.507,00 €



Accessories for Iron embossing machine NOA60

Handrails embossing roller 01 NOA60

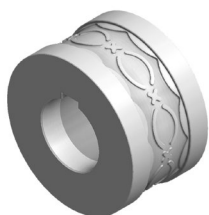

Reference: 140-11-01-00001.40

Roller to emboss a 40 mm or 1"-1/2 inches handrail
Guide 140-11-01-00401 or 140-11-01-00402 is required
Ask the manufacturer about different dimensions

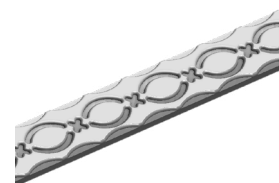

Units per machine	Material thickness	Weight	PRICE
1	From 6 to 10mm	6,5 Kg.	1.016,00 €

Handrails embossing roller 02 NOA60



Reference: 140-11-01-00002.40

Roller to emboss a 40 mm or 1"-1/2 inches handrail
Guide 140-11-01-00401 or 140-11-01-00402 is required
Ask the manufacturer about different dimensions

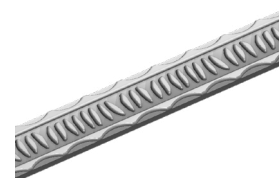

Units per machine	Material thickness	Weight	PRICE
1	From 6 to 10mm	6,5 Kg.	1.016,00 €

Handrails embossing roller 03 NOA60

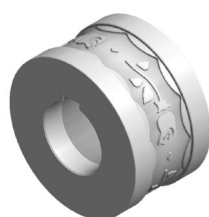

Reference: 140-11-01-00003.40

Roller to emboss a 40 mm or 1"-1/2 inches handrail
Guide 140-11-01-00401 or 140-11-01-00402 is required
Ask the manufacturer about different dimensions



Units per machine	Material thickness	Weight	PRICE
1	From 6 to 10mm	6,5 Kg.	1.016,00 €

Handrails embossing roller 04 NOA60

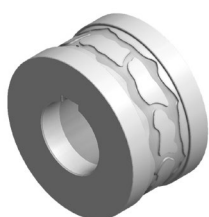

Reference: 140-11-01-00004.40

Roller to emboss a 40 mm or 1"-1/2 inches handrail
Guide 140-11-01-00401 or 140-11-01-00402 is required
Ask the manufacturer about different dimensions

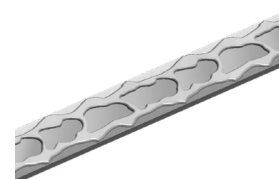

Units per machine	Material thickness	Weight	PRICE
1	From 6 to 10mm	6,5 Kg.	1.016,00 €

Accessories for Iron embossing machine NOA60

Handrails embossing roller 05 NOA60

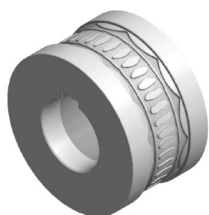

Reference: 140-11-01-00005.40

Roller to emboss a 40 mm or 1"-1/2 inches handrail
Guide 140-11-01-00401 or 140-11-01-00402 is required
Ask the manufacturer about different dimensions

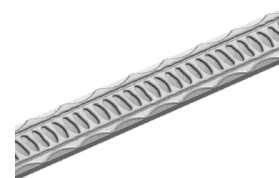

Units per machine	Material thickness	Weight	PRICE
1	From 6 to 10mm	6,5 Kg.	1.016,00 €

Handrails embossing roller 06 NOA60



Reference: 140-11-01-00006.40

Roller to emboss a 40 mm or 1"-1/2 inches handrail
Guide 140-11-01-00401 or 140-11-01-00402 is required
Ask the manufacturer about different dimensions



Units per machine	Material thickness	Weight	PRICE
1	From 6 to 10mm	6,5 Kg.	1.016,00 €

Handrails embossing roller 07 NOA60



Reference: 140-11-01-00007.40

Roller to emboss a 40 mm or 1"-1/2 inches handrail
Guide 140-11-01-00401 or 140-11-01-00402 is required
Ask the manufacturer about different dimensions



Units per machine	Material thickness	Weight	PRICE
1	From 6 to 10mm	6,5 Kg.	1.016,00 €

Handrails embossing roller 08 NOA60



Reference: 140-11-01-00008.40

Roller to emboss a 40 mm or 1"-1/2 inches handrail
Guide 140-11-01-00401 or 140-11-01-00402 is required
Ask the manufacturer about different dimensions



Units per machine	Material thickness	Weight	PRICE
1	From 6 to 10mm	6,4 Kg.	1.016,00 €

Accessories for Iron embossing machine NOA60

Handrails embossing roller 09 NOA60

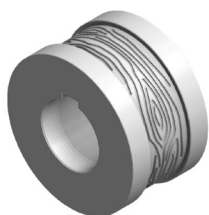

Reference: 140-11-01-00009

Roller to emboss handrail up to 60 mm

Guide 140-11-01-00401, 140-11-01-00402 or 140-11-01-00400 is required

Ask the manufacturer about different dimensions

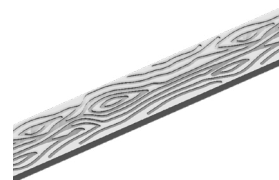

Units per machine	Material thickness	Weight	PRICE
1	From 6 to 10mm	6,1 Kg.	1.016,00 €

Handrails embossing roller 10 NOA60



Reference: 140-11-01-00010.40

Roller to emboss a 40 mm or 1"-1/2 inches handrail

Guide 140-11-01-00401 or 140-11-01-00402 is required

Ask the manufacturer about different dimensions



Units per machine	Material thickness	Weight	PRICE
1	From 6 to 10mm	6,5 Kg.	1.016,00 €

Handrails embossing roller 11 NOA60



Reference: 140-11-01-00011.40

Roller to emboss a 40 mm or 1"-1/2 inches handrail

Guide 140-11-01-00401 or 140-11-01-00402 is required

Ask the manufacturer about different dimensions



Units per machine	Material thickness	Weight	PRICE
1	From 6 to 10mm	6,5 Kg.	1.016,00 €

Handrails embossing roller 12 NOA60



Reference: 140-11-01-00012.40

Roller to emboss a 40 mm or 1"-1/2 inches handrail

Guide 140-11-01-00401 or 140-11-01-00402 is required

Ask the manufacturer about different dimensions



Units per machine	Material thickness	Weight	PRICE
1	From 6 to 10mm	6,5 Kg.	1.016,00 €

Accessories for Iron embossing machine NOA60

Handrails embossing roller 13 NOA60



Reference: 140-11-01-00013.40

Roller to emboss a 40 mm or 1"-1/2 inches handrail
Guide 140-11-01-00401 or 140-11-01-00402 is required
Ask the manufacturer about different dimensions

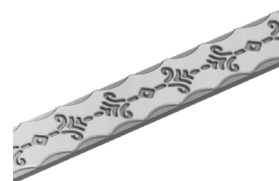

Units per machine	Material thickness	Weight	PRICE
1	From 6 to 10mm	6,5 Kg.	1.016,00 €

Handrails embossing roller 14 NOA60



Reference: 140-11-01-00014.40

Roller to emboss a 40 mm or 1"-1/2 inches handrail
Guide 140-11-01-00401 or 140-11-01-00402 is required
Ask the manufacturer about different dimensions



Units per machine	Material thickness	Weight	PRICE
1	From 6 to 10mm	6,5 Kg.	1.016,00 €

Handrails embossing roller 15 NOA60



Reference: 140-11-01-00015.40

Roller to emboss a 40 mm or 1"-1/2 inches handrail
Guide 140-11-01-00401 or 140-11-01-00402 is required
Ask the manufacturer about different dimensions

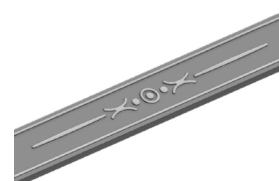

Units per machine	Material thickness	Weight	PRICE
1	From 6 to 10mm	6,4 Kg.	776,00 €

Handrails embossing roller 16 NOA60



Reference: 140-11-01-00016.40

Roller to emboss a 40 mm or 1"-1/2 inches handrail
Guide 140-11-01-00401 or 140-11-01-00402 is required
Ask the manufacturer about different dimensions



Units per machine	Material thickness	Weight	PRICE
1	From 6 to 10mm	6,4 Kg.	776,00 €

Accessories for Iron embossing machine NOA60

Handrails embossing roller 17 NOA60



Reference: 140-11-01-00017.40

Roller to emboss a 40 mm or 1"-1/2 inches handrail
Guide 140-11-01-00401 or 140-11-01-00402 is required
Ask the manufacturer about different dimensions



Units per machine	Material thickness	Weight	PRICE
1	From 6 to 10mm	6,4 Kg.	776,00 €

Handrails embossing roller 18 NOA60

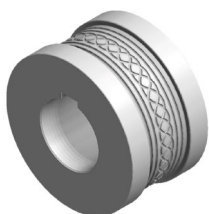

Reference: 140-11-01-00018.40

Roller to emboss a 40 mm or 1"-1/2 inches handrail
Guide 140-11-01-00401 or 140-11-01-00402 is required
Ask the manufacturer about different dimensions

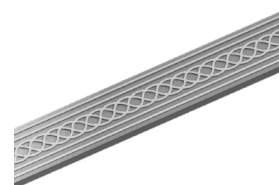

Units per machine	Material thickness	Weight	PRICE
1	From 6 to 10mm	6,4 Kg.	776,00 €

Handrails embossing roller 19 NOA60



Reference: 140-11-01-00019.40

Roller to emboss a 40 mm or 1"-1/2 inches handrail
Guide 140-11-01-00401 or 140-11-01-00402 is required
Ask the manufacturer about different dimensions



Units per machine	Material thickness	Weight	PRICE
1	From 6 to 10mm	6,4 Kg.	1.016,00 €

Handrails embossing roller 20 NOA60



Reference: 140-11-01-00020.40

Roller to emboss a 40 mm or 1"-1/2 inches handrail
Guide 140-11-01-00401 or 140-11-01-00402 is required
Ask the manufacturer about different dimensions

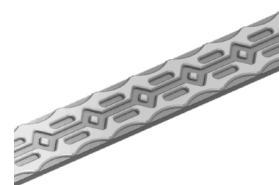

Units per machine	Material thickness	Weight	PRICE
1	From 6 to 10mm	6,5 Kg.	1.016,00 €

Accessories for Iron embossing machine NOA60

Handrails embossing roller 21 NOA60



Referencia: 140-11-01-00021.50

Rodillo para grabar pasamano de 50 mm o 2" pulgadas.

Para su uso es necesaria la guía 140-11-01-00401 o la guía 140-11-01-00402.

Para medidas distintas consultar con el fabricante.

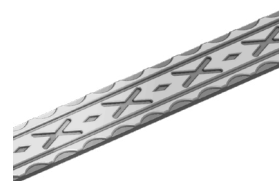

Units per machine	Material thickness	Weight	PRICE
1	From 6 to 10mm	6,4 Kg.	1.016,00 €

Handrails embossing roller 22 NOA60



Referencia: 140-11-01-00022.40

Rodillo para grabar pasamano de 40 mm o 1" 1/2 pulgadas.

Para su uso es necesaria la guía 140-11-01-00401 o la guía 140-11-01-00402.

Para medidas distintas consultar con el fabricante.



Units per machine	Material thickness	Weight	PRICE
1	From 6 to 10mm	6,4 Kg.	1.016,00 €

Handrails and square bars embossing roller 23 NOA60

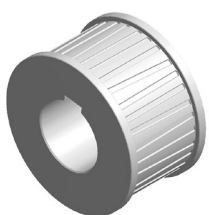

Referencia: 140-11-01-00023

Roller to emboss handrail up to 60 mm and square bar up to 25 mm.

Guide 140-11-01-00300, 140-11-01-00400, 140-11-01-00401, 140-11-01-00402, 140-11-01-00403 or 140-11-01-00404 is required

Ask the manufacturer about different dimensions

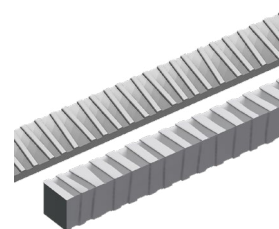

Units per machine	Material thickness	Weight	PRICE
1	From 6 to 10mm	6 Kg.	776,00 €

Handrails embossing roller 24 NOA60



Reference: 140-11-01-00024.40

Roller to emboss a 40 mm or 1"-1/2 inches handrail

Guide 140-11-01-00401 or 140-11-01-00402 is required

Ask the manufacturer about different dimensions



Units per machine	Material thickness	Weight	PRICE
1	From 6 to 10mm	6,4 Kg.	776,00 €

Accessories for Iron embossing machine NOA60

Handrails embossing roller 25 NOA60

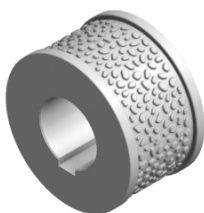

Reference: 140-11-01-00025

Roller to emboss handrail up to 60 mm

Guide 140-11-01-00401, 140-11-01-00402 or 140-11-01-00400 is required

Ask the manufacturer about different dimensions

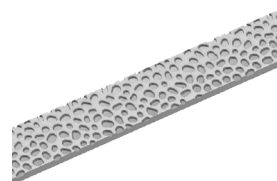

Units per machine	Material thickness	Weight	PRICE
1	From 6 to 10mm	6,3 Kg.	1.177,00 €

Roller for the side marking of flat bar NOA60

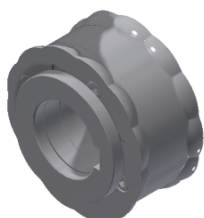

Reference: 140-11-01-00028

Sectioned roller to emboss different flat bar sizes on the same kit. Adjustable to flat bars of 25mm o 1", 30mm o 1" 1/4, 40mm o 1" 1/2 and 50mm o 2".

Guide 140-11-01-00401, 140-11-01-00402, 140-11-01-00403 or 140-11-01-00404 is required

Ask the manufacturer about different dimensions

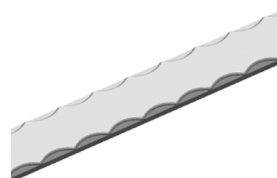

Units per machine	Material thickness	Weight	PRICE
1	From 5 to 12mm	12,5 Kg.	1.070,00 €

Rollerstand



Reference: 140-00-00-00004

Seven-rollers stand

Ask the manufacturer about different dimensions

Working Height	Dimensions	Load capacity	Weight	PRICE
650 / 1200 mm	2050x470 mm	800 Kg.	65 Kg.	589,00 €



Accessories for Iron embossing machine NOA60

Entrance guide for 60 mm handrail NOA60

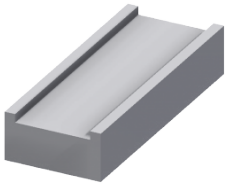

Reference: 140-11-01-00400
Entrance guide for 60 mm handrail.

Weight	PRICE
4,3 Kg.	135,00 €

Entrance guide for 40 and 50 mm handrail NOA60

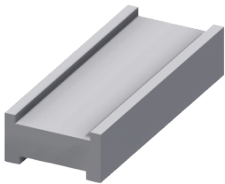

Reference: 140-11-01-00401
Inlet guide for 40 and 50 mm handrail

Weight	PRICE
4 Kg.	135,00 €

Entrance guide for 1" 1/2 y 2" inches handrail NOA60

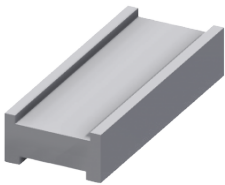

Reference: 140-11-01-00402
Inlet guide for 1" 1/2 and 2" inches handrail.

Weight	PRICE
4 Kg.	135,00 €

Entrance guide for 25 and 30mm handrail NOA60

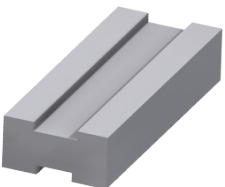

Reference: 140-11-01-00403
Inlet guide for 25 and 30 mm handrail.

Weight	PRICE
4,3 Kg.	135,00 €

Entrance guide for 1" and 1" 1/4 inches handrail NOA60

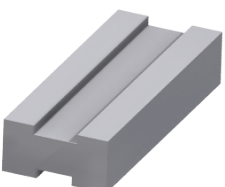

Reference: 140-11-01-00404
Inlet guide for 1" and 1" 1/4 inches handrail.

Weight	PRICE
4,3 Kg.	135,00 €

Accessories for Iron embossing machine NOA60

Handrails embossing roller 201 NOA60

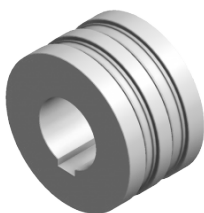

Reference: 140-11-01-00201

Roller to emboss 12 and 15 mm or 1/2 inch handrail. For clamp forming

Guide 140-11-01-00200 is required

Ask the manufacturer about different dimensions

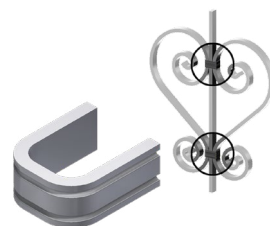

Units per machine	Material thickness	Weight	PRICE
1	From 1 to 4 mm	6,5 Kg.	776,00 €

Handrails embossing roller 202 NOA60

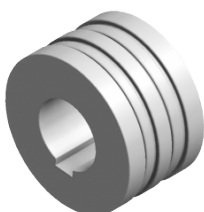

Reference: 140-11-01-00202

Roller to emboss 12 and 15 mm or 1/2 inch handrail. For clamp forming

Guide 140-11-01-00200 is required

Ask the manufacturer about different dimensions

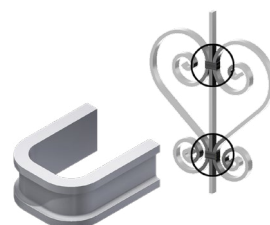

Units per machine	Material thickness	Weight	PRICE
1	From 1 to 4 mm	6,6 Kg.	776,00 €

Entrance guide for 12mm or 1/2" inch and 15 mm handrail NOA60

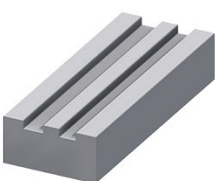

Reference: 140-11-01-00200

Entrance guide for 12 mm and 15 mm or 1/2" inch handrail

Weight	PRICE
4,6 Kg.	135,00 €

Accessories for Iron embossing machine NOA60

Set of handrails and square bars embossing rollers 26 NOA60

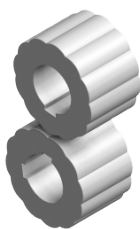

Reference: 140-11-01-00026

Rollers to emboss handrail up to 60 mm and square bar up to 20 mm or 3/4" inch

Guide 140-11-01-00300, 140-11-01-00400, 140-11-01-00401, 140-11-01-00402, 140-11-01-00403 or 140-11-01-00404 is required

To emboss edge square bar, an entrance guide is required 140-11-01-00027

Ask the manufacturer about different dimensions

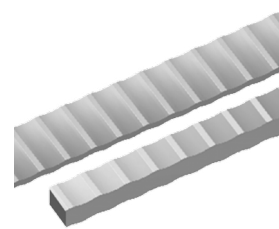

Units per machine	Material thickness	Weight	PRICE
1	--	11,4 Kg.	1.710,00 €

Entrance guide for edge square bar NOA60

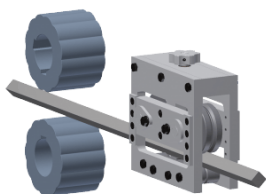

Reference: 140-11-01-00027

Entrance guide to emboss edge square bar up to 20mm or 3/4" inch

Set of embossing rollers 140-11-01-00026 is required

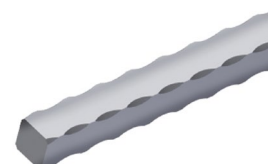

Weight	PRICE
18 Kg.	1.070,00 €

Set of square bar embossing rollers 301 NOA60



Reference: 140-11-01-00301

Rollers to emboss square bar up to 10 mm or 3/8", 14 mm or 9/16" and 20 mm or 3/4" inch

Guide 140-11-01-00300 is required

Ask the manufacturer about different dimensions

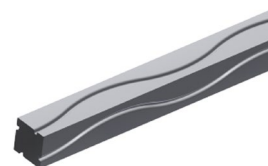

Units per machine	Material thickness	Weight	PRICE
1	--	12,6 Kg.	1.016,00 €

Set of square bar embossing rollers 302 NOA60



Referencia: 140-11-01-00302

Rollers to emboss square bar up to 12 mm or 1/2", 16 mm or 5/8" and 18 mm.

Guide 140-11-01-00300 is required

Ask the manufacturer about different dimensions

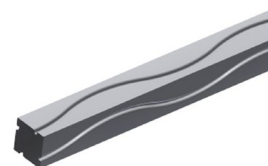

Units per machine	Material thickness	Weight	PRICE
1	--	12,6 Kg.	1.016,00 €

Accessories for Iron embossing machine NOA60

Set of square bar embossing rollers 303 NOA60



Reference: 140-11-01-00303

Rollers to emboss square bar up to 10 mm or 3/8", 14 mm or 9/16" and 20 mm or 3/4" inch

Guide 140-11-01-00300 is required

Ask the manufacturer about different dimensions

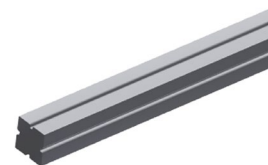

Units per machine	Material thickness	Weight	PRICE
1	--	12,9 Kg.	909,00 €

Set of square bar embossing rollers 304 NOA60



Reference: 140-11-01-00304

Rollers to emboss square bar up to 12 mm or 1/2", 16 mm or 5/8" and 18 mm.

Guide 140-11-01-00300 is required

Ask the manufacturer about different dimensions

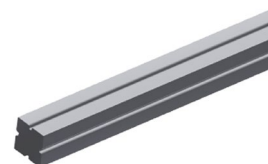

Units per machine	Material thickness	Weight	PRICE
1	--	12,9 Kg.	909,00 €

Entrance guide for square bar NOA60



Reference: 140-11-01-00300

Entrance guide for square bar of 10mm or 3/8", 12mm or 1/2", 14mm or 9/16", 16mm or 5/8", 18mm and 20 mm or 3/4" inch

Weight	PRICE
4 Kg.	135,00 €

Accessories for Iron embossing machine NOA60

Set of embossing rollers for 25 mm or 1", 30 mm or 1" 1/4, 35 and 40 mm pipes NOA60

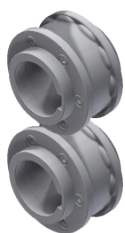

Reference: 140-11-01-00500

Set of sectioned rollers to emboss different square or rectangular pipe sizes with the same set. Adjustable to the following pipes:

Square pipes: 25mm or 1", 30mm or 1" 1/4, 35 and 40mm

Rectangular pipes: 25x20mm or 1"x3/4", 30x20mm or 1"1/4x3/4", 30x25mm, 35x20mm, 35x25mm, 40x20mm, 40x25mm, 40x30mm, 40x35mm

Guide 140-11-01-00501 or 140-11-01-00502 is required

Ask the manufacturer about different dimensions



Set per machine	Material minimum thickness suggested by manufacturer	Weight	PRICE
1	3 mm	12 Kg.	1.187,00 €

Inlet guide for 25 mm or 1" and 30 mm or 1" 1/4 pipe NOA60

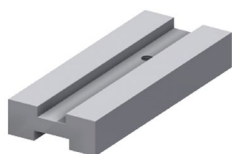

Reference: 140-11-01-00501

Inlet guide for 25 mm or 1" and 30 mm or 1" 1/4 pipe

Weight	PRICE
3 Kg.	135,00 €

Inlet guide for 35 and 40 mm pipe NOA60

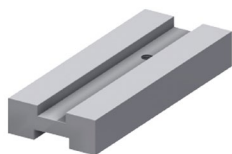

Reference: 140-11-01-00502

Inlet guide for 35 and 40 mm pipe

Weight	PRICE
2,8 Kg.	135,00 €



Accessories for Iron embossing machine NOA60

Set of embossing rollers for 50 and 60mm pipes NOA60

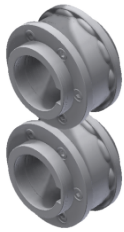

Reference: 140-11-01-00503

Set of sectioned rollers to emboss different square or rectangular pipe sizes with the same set. Adjustable to the following pipes:

Square pipes: 50mm or 60mm

Rectangular pipes: 50x20mm, 50x25mm, 50x30mm, 50x35mm, 50x40mm, 50x45mm, 60x20mm, 60x25mm, 60x30mm, 60x35mm, 60x40mm, 60x45mm, 60x50mm or 60x55mm

Guide 140-11-01-00505 or 140-11-01-00506 is required

Ask the manufacturer about different dimensions

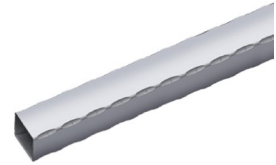

Set per machine	Material minimum thickness suggested by manufacturer	Weight	PRICE
1	3 mm	6 Kg.	1.187,00 €

Inlet guide for 50 mm pipe NOA60



Reference: 140-11-01-00505

Inlet guide for 50 mm pipe

Weight	PRICE
2,4 Kg.	135,00 €

Inlet guide for 60 mm pipe NOA60



Reference: 140-11-01-00506

Inlet guide for 60 mm pipe

Weight	PRICE
2,2 Kg.	135,00 €

Accessories for Iron embossing machine NOA60

Set of embossing rollers for 1" 1/2, 2" and 2" 1/2 inches pipes NOA60

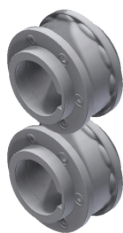

Reference: 140-11-01-00507

Set of sectioned rollers to emboss different square or rectangular pipe sizes with the same set. Adjustable to the following pipes:

Square pipes: 1" 1/2, 2" and 2" 1/2 inches

Rectangular pipes: 1"1/2x3/4", 1"1/2x1", 2"x1", 2"x1"1/4, 2"x1"1/2, 2"1/2x1"1/2 inches

Guide 140-11-01-00508, 140-11-01-00509

or 140-11-01-00510 is required

Ask the manufacturer about different dimensions

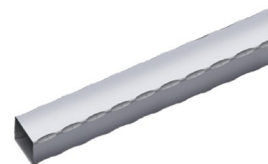

Set per machine	Material minimum thickness suggested by manufacturer	Weight	PRICE
1	3 mm	6 Kg.	1.187,00 €

Inlet guide for 1" 1/2 inches pipe NOA60



Reference: 140-11-01-00508

Inlet guide for 1" 1/2 inches pipe

Weight	PRICE
2,6 Kg.	135,00 €

Inlet guide for 2" inches pipe NOA60



Reference: 140-11-01-00509

Inlet guide for 2" inches pipe

Weight	PRICE
2,4 Kg.	135,00 €

Inlet guide for 2" 1/2 inches pipe NOA60



Reference: 140-11-01-00510

Inlet guide for 2" 1/2 inches pipe

Weight	PRICE
2,2 Kg.	135,00 €

Hydraulic press for locks

Hydraulic press for locks PI85

Hydraulic Press for locks PI85 Nargesa, is a NOVELTY in the locksmith's branch. It was patented by Nargesa from year 2006. It makes us lead this kind of machinery. It is suitable for 85% locks in the market, regarding trademarks and models.

Reference	100-07-01-001
Engine power	0,75 KW / 1 HP
Three-phased tension	230 / 400 V
Pipe thickness	1,5 and 2mm
Lock entrance	Adjustable 18 to 37mm
Dimensions	1500x570x1470mm
Weight	200 Kg
PRICE	5.440,00 €





Accessories for Hydraulic press for locks

Tooling for 35X35. Wall thickness 1,5mm

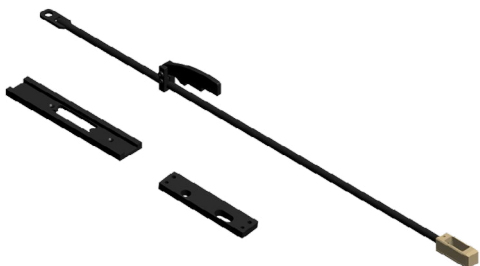

Reference	140-07-01-00001
Pipe	35 x 35 mm
Thickness	1,5 mm
Pieces by tooling	3 units
Weight	5 Kg
PRICE	429,00 €

Tooling for 40x40mm up to 40x80mm. Wall 1,5mm

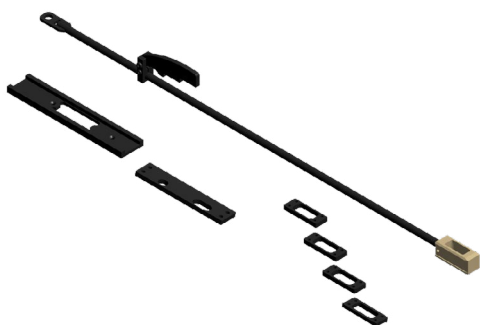

Reference	140-07-01-00003
Pipe	40x40 mm, 40x50 mm, 40x60 mm, 40x70 mm, 40x80mm
Thickness	1,5 mm
Pieces by tooling	8 units
Weight	5,3 Kg
PRICE	429,00 €

Tooling for 40x40mm up to 40x80mm. Wall 2mm

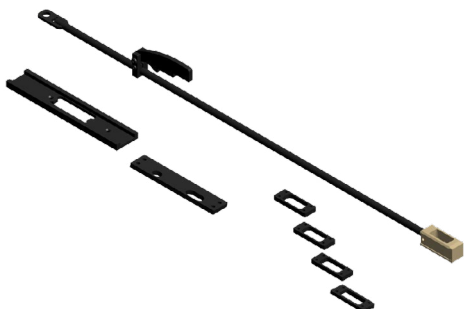

Reference	140-07-01-00004
Pipe	40x40 mm, 40x50 mm, 40x60 mm, 40x70 mm, 40x80mm
Thickness	2 mm
Pieces by tooling	8 units
Weight	5,3 Kg
PRICE	429,00 €



Accessories for Hydraulic press for locks

Tooling for 50x50mm up to 50x80mm. Wall 1,5mm

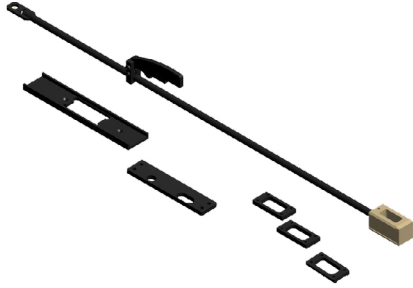

Reference	140-07-01-00005
Pipe	50x50 mm, 50x60 mm, 50x70 mm 50x80mm
Thickness	1,5 mm
Pieces by tooling	7 units
Weight	5,5 Kg
PRICE	429,00 €

Tooling for 50x50 up to 50x80mm. Wall 2mm

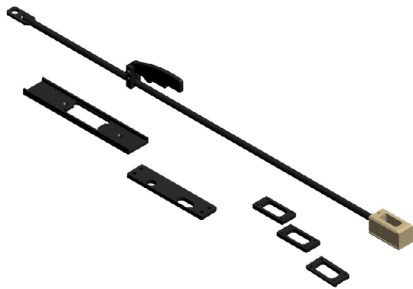

Reference	140-07-01-00006
Pipe	50x50 mm, 50x60 mm, 50x70 mm 50x80mm
Thickness	2 mm
Pieces by tooling	7 units
Weight	5,5 Kg
PRICE	429,00 €

Consumables

Hydraulic Oil SIL POWER HV46



Reference: 060-BA-00016

Extreme Pressure hydraulic fluid for oleo dynamic circuits, power transmission systems that work under severe temperature and pressure conditions. Micro-filtered. It incorporates a viscosity level improver.

Container: 20L

Weight: 20 Kg

** Recommended for Nargesa Press Brakes*

PRICE: 146,00 €

Hydraulic Oil SIL POWER HV68



Reference: 060-BA-00017

Extreme Pressure hydraulic fluid for oleo dynamic circuits, power transmission systems that work under severe temperature and pressure conditions. Micro-filtered. It incorporates a vis-cosity level improver

Container: 20L

Weight: 20 Kg

PRICE: 161,00 €

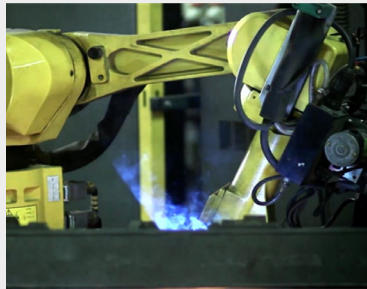

PRADA NARGESA, S.L.

Ctra. de Garrigàs a Sant Miquel s/n 17476 Palau de Santa Eulàlia (Girona) Spain
Tel. +34 972 568 085 www.nargesa.com nargesa@nargesa.com